

# Haojue

## PARTS CATALOGUE

# EG150X



## PREFACE

This catalogue lists the spare parts used for the following model. Please do refer to the parts catalogue and indicate the parts number and the name listed in this catalogue correctly when you need to replace the spare parts.

Design Code	Factory Reference No. (Abbr. form in the catalogue)	Engine Reference No.	Engine Cad No.
EG150X	KF1136U92A-XXB05	EG36U32-E05	10091H36030H000

### 一、 How to place an order for spare parts?

#### 1. Required document:

The number must be provided as follow when order the spare parts:

- (a) The Engine parts: parts number and the Engine number
- (b) The Body parts: parts number and the Frame number

#### 2. Revision

The Revised Version would be published at a suitable time when the parts Catalogue needed to be revised or renewed. In this case, the edition number would be marked on the cover. The parts would have some difference because our products are improved continuously and the modified parts no. will not be informed before the new edition published.

### 二、 How to use the parts catalogue?

#### 1. Size

The unit of the parts' size indicated in the catalogue is 'mm', for example:

Parts name	Description
Bolt 6×12	Diameter 6mm, Length 12mm

O Ring D: 3.0, ID: 29.5	Section diameter 3mm, inner diameter 29.5mm
Bearing 35×72×17	Inner diameter 35mm, Outer diameter 72mm, Thickness 17mm

#### 2. Abbr.

The meaning of the Abbreviations in the catalogue are as the followings:

D: Section diameter NT: Number of Teeth L: Length ID: Inner diameter W: Width

OPT: Optional T: Thickness OD: Outer diameter OS: Over size

STD: Standard US: Under size LH: Left hand side RH: Right hand side

#### 3. Assy and the inner parts

The part number with a hyphen '-' in the front means this part could be supplied with the Assy (or the comp.), also could be supplied separately.

For example:

Item 1 CYLINDER HEAD ASSY

Item1-1 PIN,CAMSHAFT COVER

That means Item1-1 can be supplied with Item 1 and aslo can be supplied separately.

#### 4. The illustrations in the catalogue are just for the purpose to distinguish the parts. There might be some discrepancies between the illustrations and the real parts.. Furthermore, the illustrations can not be used for the assembling purpose. When assembling, pls use the Service Manual of the relative models.

#### 5. The instruction for the color parts

The catalogue lists are being supervised by color code.

For example: Assy,Fuel Tank 44100H22000HF01 F01 is the colour code and means "RED".

When place an order for the color parts, please use the correct parts number (with the color code), based on the compound color sheet of the models.

**This catalogue is edited according to the datas before 2017-6-29. The modification after that time should refer to the latest SPS(Spare Parts Modification notice).**

**EG150X COLOR TABLE KF1136U92A-XXB05 3 COLOR STYLES**

REF. NO.	DESCRIPTION	PART NO.	a01 RED	a03 BLACK	a04 BLUE	REMARKS
1	FUEL TANK SET	44011H11AM0H000	F01	F02	F03	
2	TAPE SET, FUEL TANK	68110H11A20H000	R94	R96	R95	NOT SUPPLY
3	TAPE, Haojue LOGO	68170H11A10H000	SIL	SIL	SIL	NOT SUPPLY
4	COVER, FRAME, L	47211H11A00H000	A39	A28	A30	
5	TAPE SET, FRAME COVER STRIPE, L	68140H11A20H000	R94	R96	R95	
6	COVER, FRAME, R	47111H11A00H000	A39	A28	A30	
7	TAPE SET, FRAME COVER STRIPE, R	68130H11A20H000	R94	R96	R95	
8	COWLING SET	94041H11A30H000	A39	A28	A30	
9	COVER, SEAT TAIL, L	45512H11A01H000	A39	A28	A30	
10	COVER, SEAT TAIL, CTR	45513H11A00H000	104	541	608	
11	COVER, SEAT TAIL, R	45511H11A01H000	A39	A28	A30	
12	FENDER, FRONT	53111H11A00H000	104	541	608	
13	WHEEL COMP, FRONT	54110H11A10H000	801	801	801	
14	WHEEL COMP, REAR	64150H11A10H000	801	801	801	



**INFORMATION ILLUSTRATION INDEX**

**1**

**ENGINE & TRANSMISSION**

**2**

**ELECTRICAL**

**3**

**BODY**

**4**

**PARTS NUMBER INDEX**

**5**





Fig. 1 CYLINDER HEAD&CYLINDER HEAD COVER (P07-S010-0014)

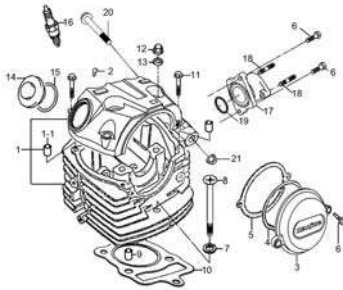

Fig. 2 CYLINDER (P07-S020-0007)

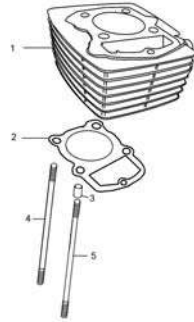

Fig. 3 CRANKCASE (P07-S030-0006)

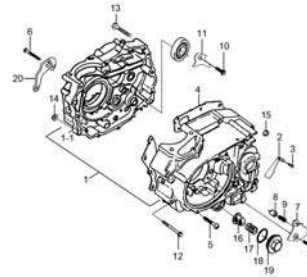

Fig. 4 CRANKCASE COVER (P07-S040-0007)

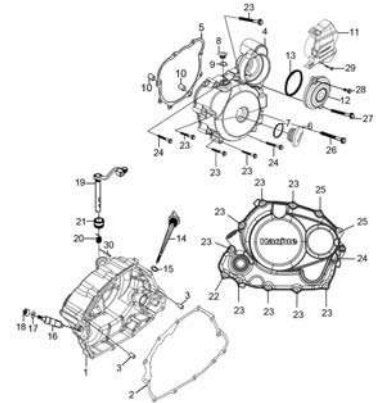

Fig. 5 CRANKSHAFT (P07-S050-0024)

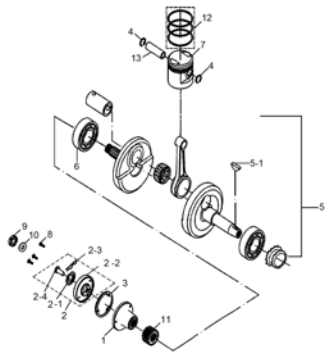

Fig. 6 STARTER CLUTCH (P07-S060-0004)

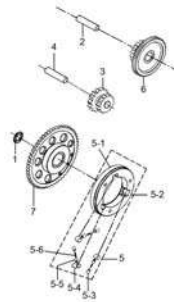

Fig. 7 CAMSHAFT-VALVE (P07-S070-0007)

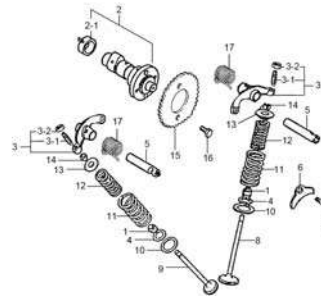
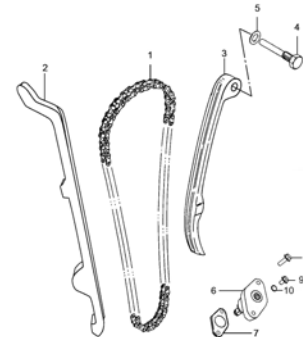

Fig. 8 CAM CHAIN (P07-S080-0008)



1

Fig. 9 CARBURETOR (P07-S090-0022)

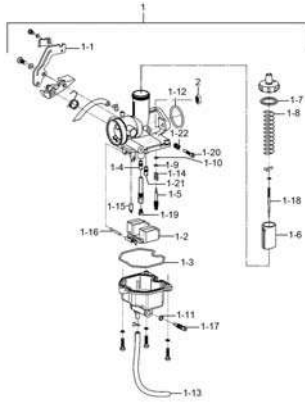

Fig. 10 AIR CLEANER (P07-S100-0009)

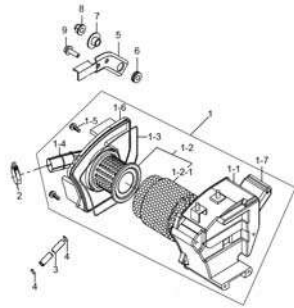

Fig. 11 MUFFLER (P07-S110-0013)

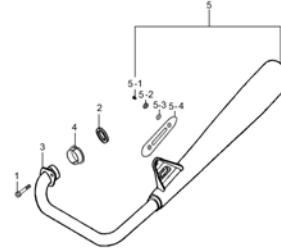

Fig. 12 2ND AIR VAVLE (P07-S120-0014)

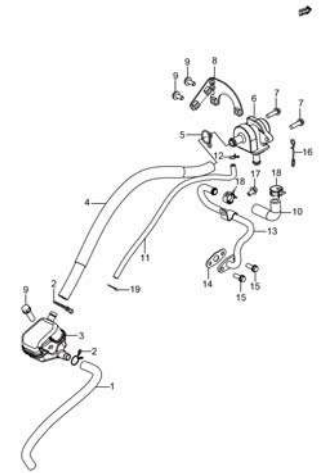

Fig. 13 OIL PUMP (P07-S130-0003)

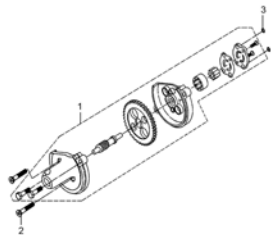

Fig. 14 CLUTCH (P07-S140-0006)

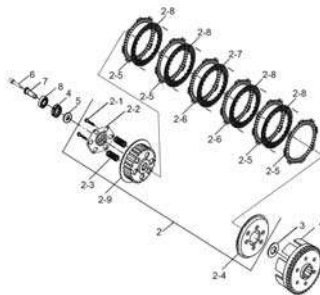

Fig. 15 TRANSMISSION (P07-S150-0009)

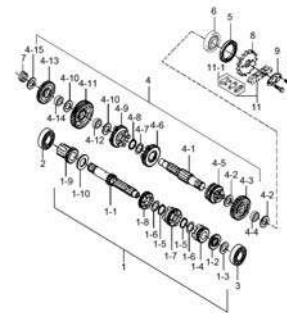

Fig. 16 GEAR SHIFTING (P07-S160-0007)

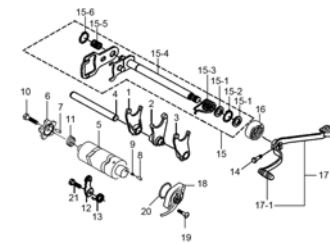

Fig. 17 KICK STARTER (P07-S165-0006)

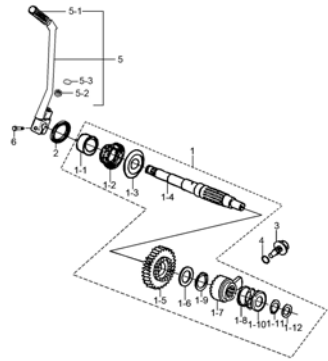

Fig. 18 STARTING MOTOR (P07-S170-0005)

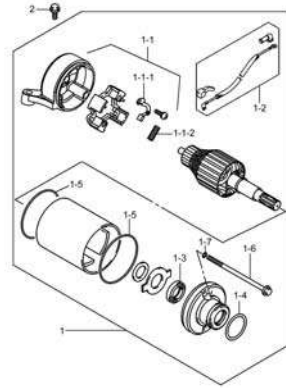

Fig. 19 MAGNETO (P07-S180-0005)

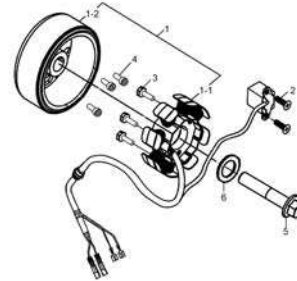

Fig. 20 BATTERY (P07-S190-0018)

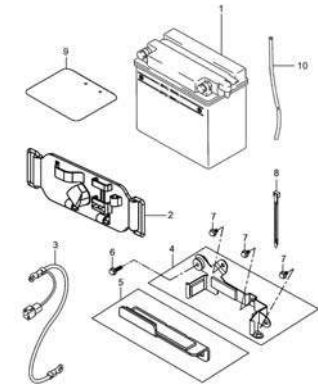

Fig. 21 ELECTRICAL (P07-S200-0017)

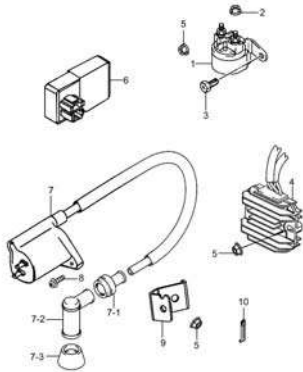

Fig. 22 SPEEDOMETER (P07-S210-0016)

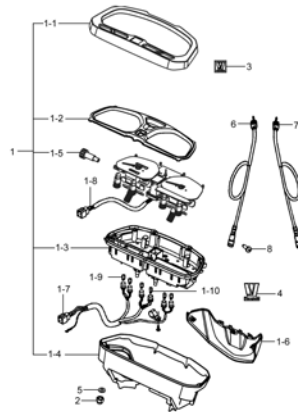

Fig. 23 HEADLAMP (P07-S220-0010)

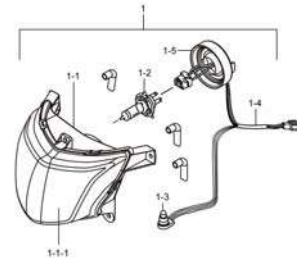

Fig. 24 TURN SIGNAL LAMP (P07-S230-0009)

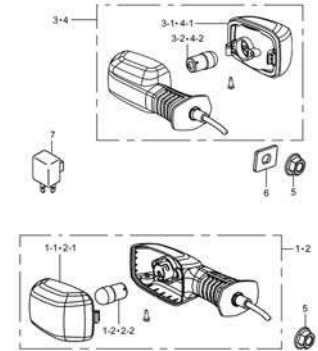

Fig. 25 REAR COMBINATION LAMP (P07-S240-0008)

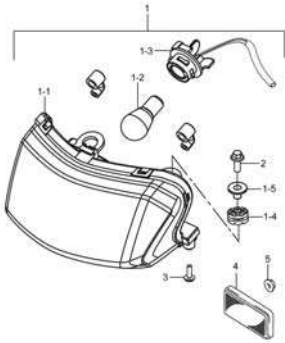

Fig. 26 WIRING HARNESS (P07-S250-0020)

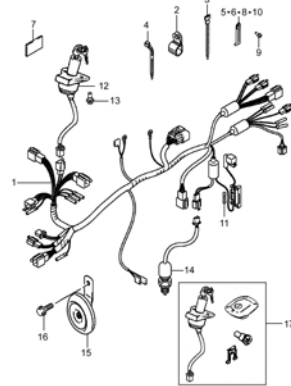

Fig. 27 FRAME (P07-S260-0042)

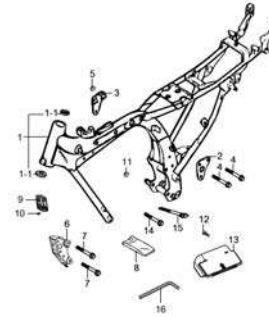

Fig. 28 STAND (P07-S270-0009)

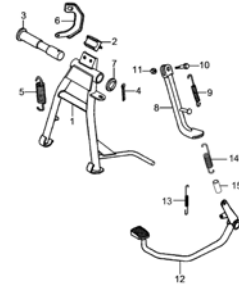

Fig. 29 FOOTREST (P07-S280-0023)

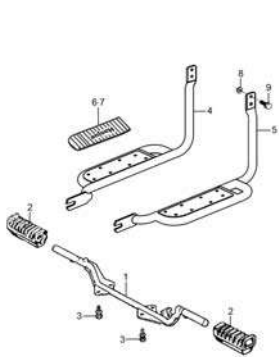

Fig. 30 FUEL TANK (P07-S290-0031)

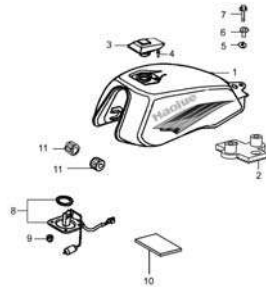

Fig. 31 FUEL COCK (P07-S300-0008)

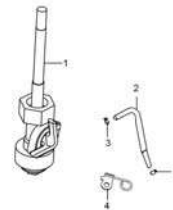

Fig. 32 FRAME COVER (P07-S310-0041)

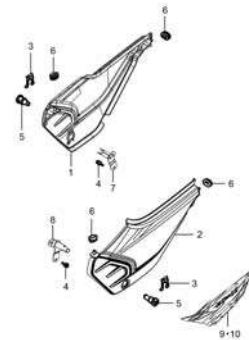

Fig. 33 FRONT FENDER (P07-S320-0013)

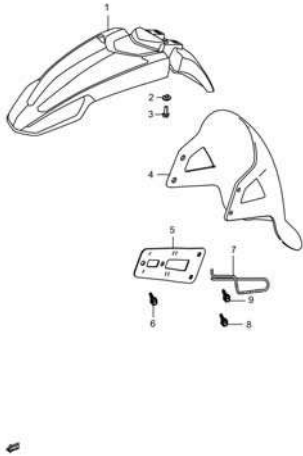

Fig. 34 HANDLEBAR (P07-S330-0023)

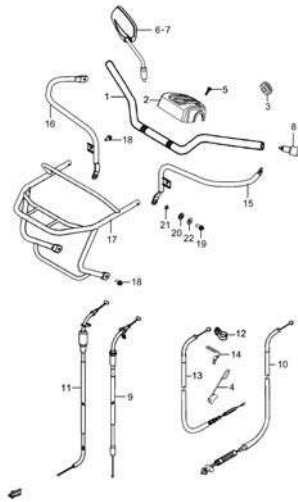

Fig. 35 HANDLE SWITCH (P07-S340-0015)

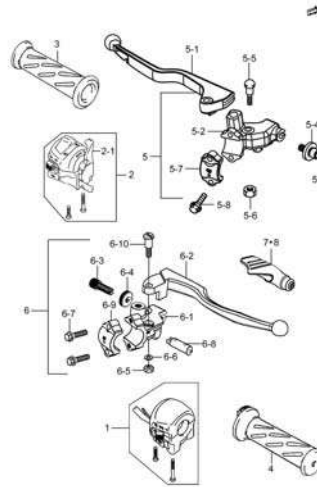

Fig. 36 REAR FENDER (P07-S350-0009)

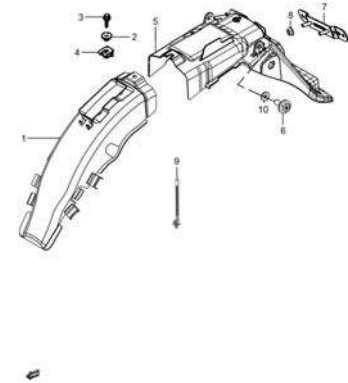

Fig. 37 COWLING (P07-S360-0007)

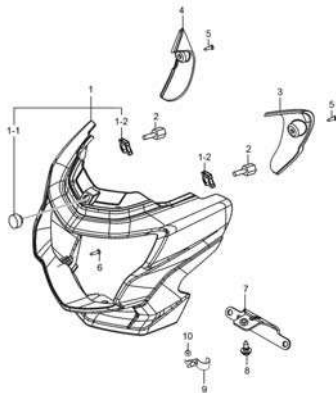

Fig. 38 LABEL (P07-S370-0033)

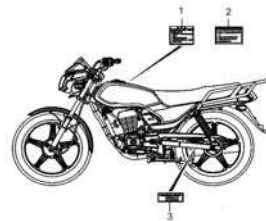

Fig. 39 SEAT (P07-S380-0006)

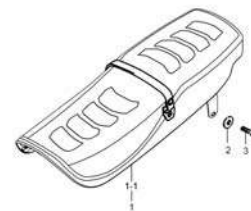

Fig. 40 COVER, SEAT TAIL (P07-S390-0022)

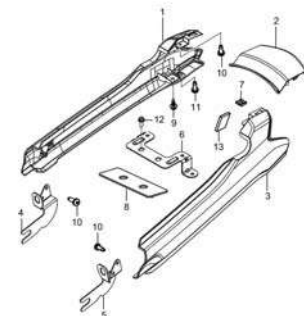

Fig. 41 STEERING STEM (P07-S400-0019)

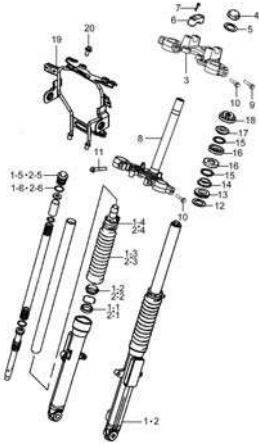

Fig. 42 FRONT WHEEL (P07-S410-0037)

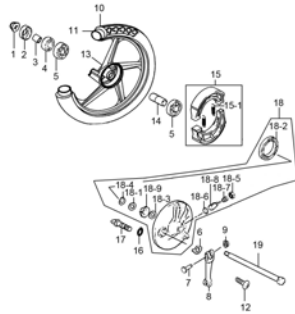

Fig. 43 REAR SWINGING ARM (P07-S440-0029)

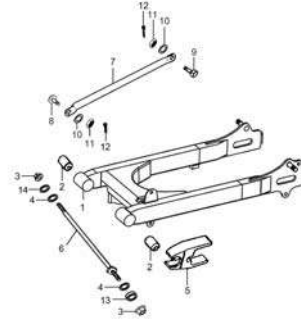

Fig. 44 REARSHOCK ABSORBER (P07-S450-0015)

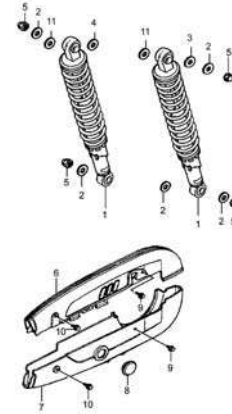

Fig. 45 REAR WHEEL (P07-S460-0063)

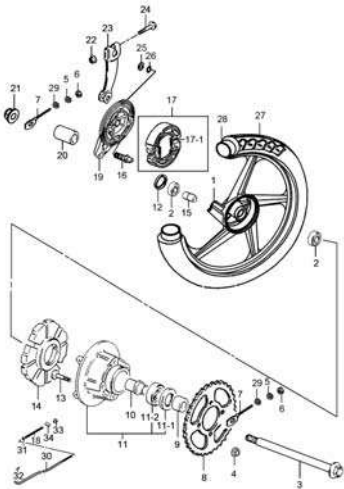

Fig. 46 BUMPER COMP (P07-S470-0007)

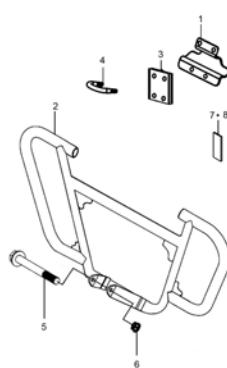

Fig. 47 CARRIER (P07-S480-0011)

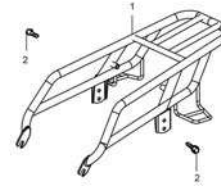

Fig.1

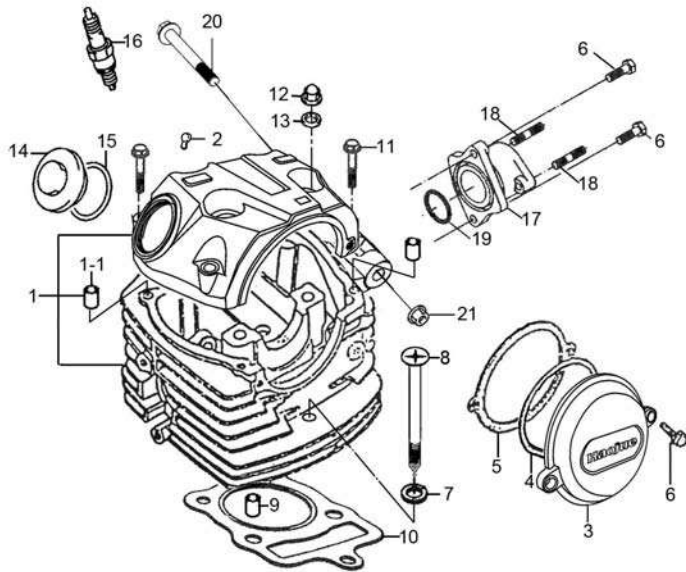

Fig.1 CYLINDER HEAD&CYLINDER HEAD COVER (P07-S010-0014)

REF. No.	PART No.	DESCRIPTION	Q'TY	REMARKS
1	11100H36Y40H000	HEAD ASSY, CYLINDER	1	
1-1	11172H35000H000	ORIENTED PIN	2	
2	11174H35000H000	OIL SEAL	1	
3	11121H36000H000	COVER, CDI	1	
4	09280H75001H000	O-RING	1	
5	11123H35000H000	WASHER, CYL HEAD COVER, L	1	
6	01547-0620A-000	BOLT	4	
7	11167H12000H000	WASHER, PLAIN (COPPER)	1	
8	09128H06008H000	BOLT, HEX WITH CROSS RECESS	1	
9	09206H10008H000	PIN	2	
10	11141H36000H000	GASKET, CYLINDER HEAD	1	
11	01547-0635A-000	BOLT	4	
12	11165H35010H000	NUT, TECTIFORM	4	
13	09160H08003H000	WASHER	4	
14	16542H36000H000	COVER, FILTER SPRING	2	
15	09280H35001H000	O-RING	2	
16	09482H33000H000	SPARK PLUG	1	
17	13111H33030H000	PIPE, INTAKE	1	
18	09108H06017H000	BOLT, STUD	2	
19	09280H34002H000	O-RING	1	
20	41919-45F00-000	BOLT, ENG MTG LOWER	1	
21	08319-3108A-000	NUT	1	

2

Fig. 2

**Fig.2 CYLINDER (P07-S020-0007)**

REF. No.	PART No.	DESCRIPTION	Q' TY	REMARKS
1	11210H36010H0B0	CYLINDER COMP	1	
2	11241H36000H000	GASKET, CYLINDER	1	
3	09206H10007H000	PIN, KNOCK	2	
4	11244H35000H000	STUD BOLT B, CYLINDER	2	
5	11243H35000H000	BOLT, CYL SYUD	2	

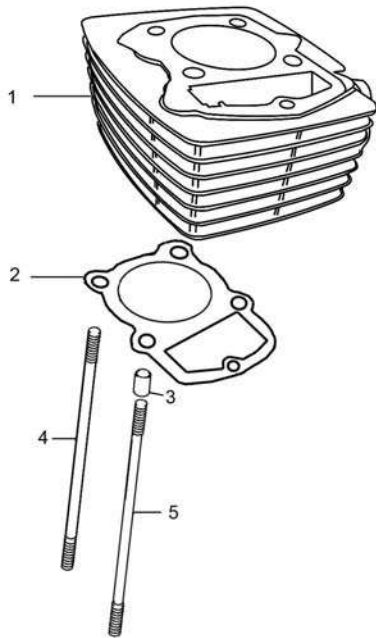

2





Fig. 3

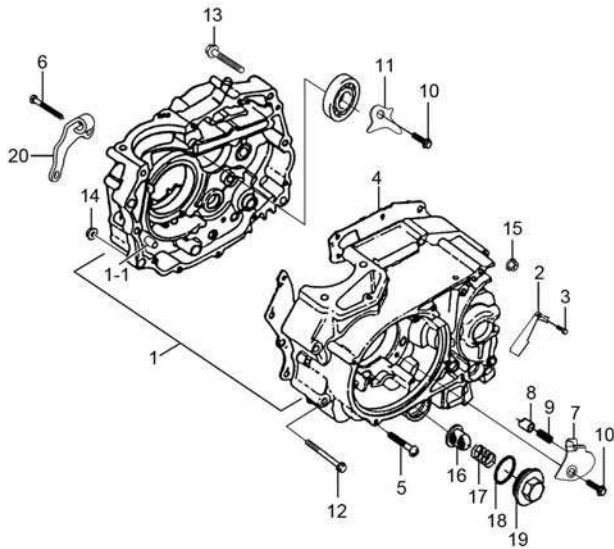

Fig.3 CRANKCASE (P07-S030-0006)

REF. No.	PART No.	DESCRIPTION	Q'TY	REMARKS
1	11300H36Y12H000	CRANKCASE ASSY	1	
1-1	09206H10007H000	PIN, KNOCK	2	
2	32115H35000H000	PLATE, WIRE PRESSURE	1	
3	01547-0612A-000	HEXAGON BOLT WITH FLANGE	1	
4	11481H36000H000	GASKET, CRANKCASE	1	
5	01547-0650A-000	BOLTS, HEXAGON HEAD FLANGE	10	
6	01547-0660A-000	BOLT	1	
7	11431H36000H000	BRACKET, BRG PUSH PIN	1	
8	12543H36000H000	PIN, BRG PUSH	1	
9	09440H07002H000	SPRING, COMPRESSION	1	
10	01547-0614A-000	BOLTS, HEXAGON HEAD FLANGE	2	
11	24741H36000H000	RETAINER, CNTR SHAFT BEARING	1	
12	09103H08015H000	BOLT, HEXAGON	2	
13	09103H10003H000	BOLT, HEXAGON	2	
14	08319-3108A-000	NUT	2	
15	08319-3110A-000	NUT	2	
16	16520H21D00H000	STRAINER, ENGINE OIL	1	
17	16541H33000H000	SPRING	1	
18	09280H35001H000	O-RING	1	
19	16542H36000H000	COVER, FILTER SPRING	1	
20	11421H33040H000	BRACKET, CLUTCH CABLE	1	

2



Fig. 4

Fig.4 CRANKCASE COVER (P07-S040-0007)

2

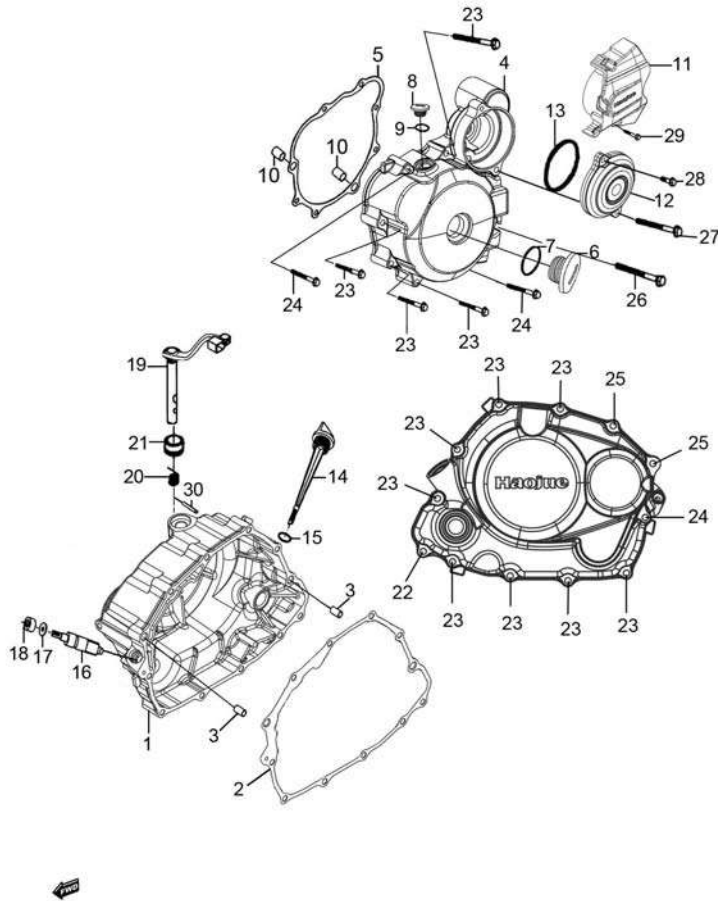

REF. No.	PART No.	DESCRIPTION	Q' TY	REMARKS
1	11340H36030H000	COVER COMP, CLUTCH	1	
2	11482H35000H000	GASKET, CRANKCASE COVER RH	1	
3	09206H08004H000	PIN, KNOCK	2	
4	11351H36031H000	COVER, MAGNETO	1	
5	11483H36000H000	GASKET, MAGNETO COVER	1	
6	09259-26023-000	PLUG	1	
7	09280-22008-000	O-RING	1	
8	09247-12104-000	PLUG, TDC	1	
9	09168-12002-000	GASKET, TDC PLUG	1	
10	09206H10007H000	PIN, KNOCK	2	
11	11361H36030H000	COVER, ENG SPROCKET	1	
12	11441H36031H000	COVER, GEAR CASE	1	
13	09280H63001H000	O-RING	1	
14	11971H12020H000	GAUGE, OIL LEVEL	1	
15	09280H18002H000	O RING	1	
16	26431H35010H000	GEAR, TACHOMETER DRIVEN	1	
17	09181H06001H000	GASKET	1	
18	09283H07001H000	OIL SEAL	1	
19	23270H3D020H000	SHAFT COMP, CLUTCH RELEASE	1	
20	09448H15001H000	SPRING, TORSION	1	
21	23285H35000H000	SEAL, RELEASE POLE	1	
22	01547-0625A-000	BOLT	1	
23	01547-0640A-000	BOLTS, HEXAGON HEAD FLANGE	12	
24	01547-0650A-000	BOLTS, HEXAGON HEAD FLANGE	3	
25	01547-0645A-000	BOLT	2	
26	01547-0660A-000	BOLT	1	
27	01547-0670A-000	BOLTS, HEXAGON HEAD FLANGE	1	
28	01547-0620A-000	BOLT	1	
29	01547-06287-000	BOLT	2	

Fig. 4

Fig.4 CRANKCASE COVER (P07-S040-0007)

REF. No.	PART No.	DESCRIPTION	Q' TY	REMARKS
30	09205H03001H000	PIN, SPRING	1	

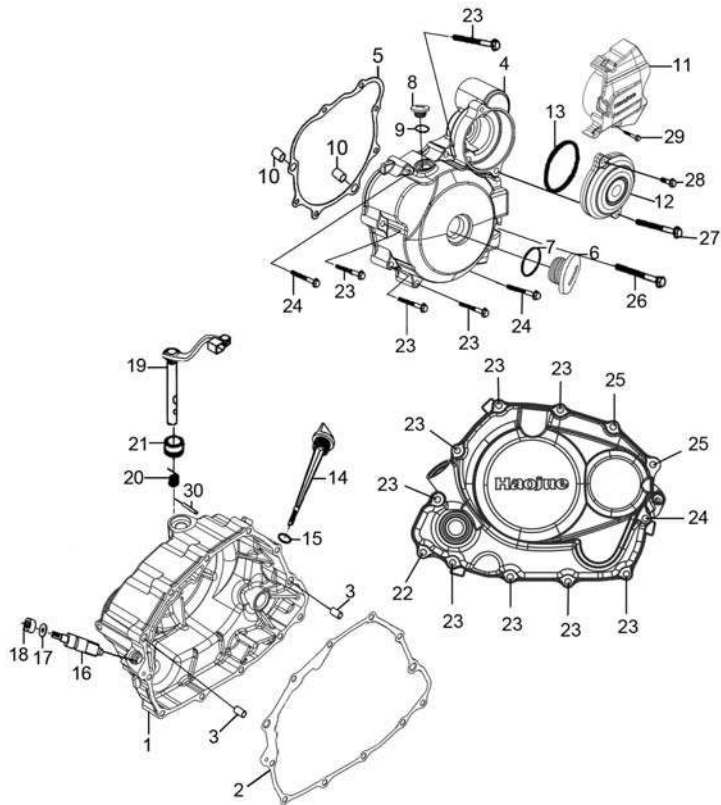

2

Fig. 5

2

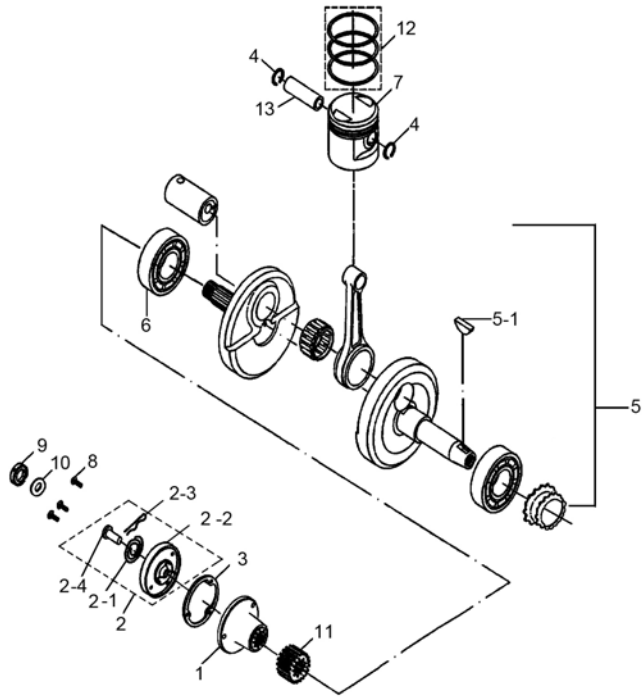

Fig.5 CRANKSHAFT (P07-S050-0024)

REF. No.	PART No.	DESCRIPTION	Q' TY	REMARKS
1	16514H35000H000	FILTER ROTOR, ENG OIL	1	
2	16520H33000H000	COVER ASSY, ENGINE OIL FILTER	1	
2-1	16532H33000H000	SPRING	1	
2-2	16521H33000H000	ROTOR COVER	1	
2-3	16551H33000H000	PIN	1	
2-4	16531H33000H000	OIL PIPE	1	
3	16561H33000H000	GASKET, ROTOR COVER	1	
4	09381H16001H000	CIRCLIP	2	
5	12200H36060H000	CRANKSHAFT ASSY	1	
5-1	09420H04002H000	KEY	1	
6	09262H28004H000	BEARING	1	
7	12111H36020H0B0	PISTON	1	
8	02122-0512A-000	CROSS RECESSED HEAD SCREW	3	
9	21346H3E000H000	NUT, LOCK	1	
10	16581H33000H000	WASHER	1	
11	21111H35000H000	GEAR, PRIMARY DRIVE	1	
12	12140H36060H000	RING SET, PISTON	1	
13	12151H36000H000	PIN, PISTON	1	

Fig. 6

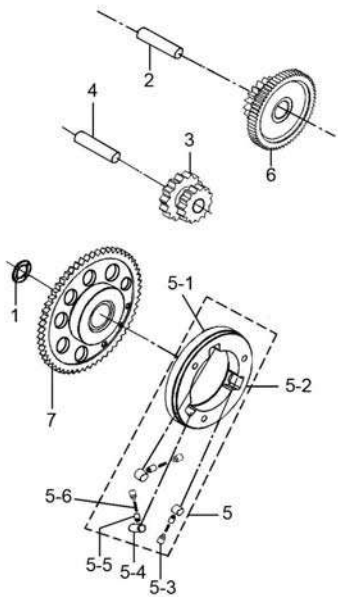

Fig.6 STARTER CLUTCH (P07-S060-0004)

REF. No.	PART No.	DESCRIPTION	Q' TY	REMARKS
1	12623H3F000H000	WASHER, STARTER CLUTCH GAER	1	
2	12683H36000H000	SHAFT, GEAR 1ST	1	
3	12651H36000H000	GEAR, STARTER IDLE	1	
4	12691H36000H000	SHAFT, GEAR 2ND	1	
5	12630H33001H000	HUB COMP, STARTER CLUTCH	1	
5-1	12642H33000H000	SHIM	1	
5-2	12631H33000H000	HUB STARTER CLUTCH	1	
5-3	12632H33001H000	PLUG, STARTER CLUTCH HUB	3	
5-4	09261H10005H000	ROLLER	3	
5-5	12633H33000H000	PIN	3	
5-6	09440H04013H000	SPRING	3	
6	12681H36000H000	GEAR, ELECTRIC STARTER	1	
7	12620H36000H000	GEAR COMP, STARTER CLUTCH	1	

2



Fig. 7

2

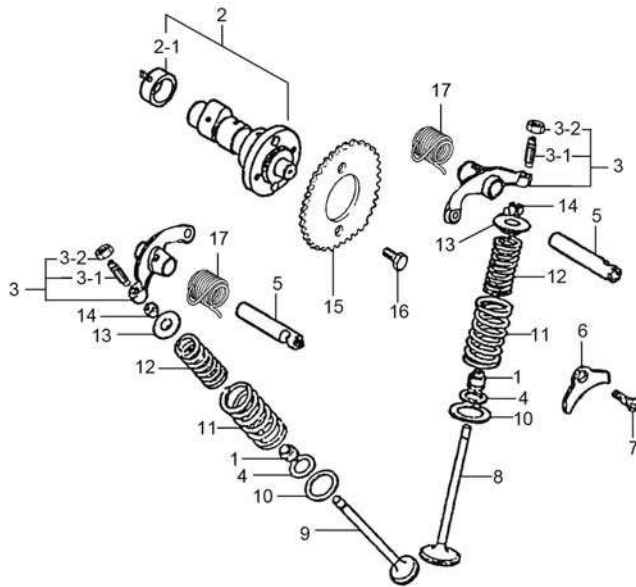

Fig.7 CAMSHAFT-VALVE (P07-S070-0007)

REF. No.	PART No.	DESCRIPTION	Q' TY	REMARKS
1	09289H05001H000	SEAL, OIL	2	
2	12710H35011H000	CAMSHAFT COMP	1	
2-1	12720H35001H000	BUSH COMP, CAMSHAFT	1	
3	12840H3C000H000	ARM COMP, VALVE ROCKER	2	
3-1	12842H3D000H000	SCREW, TAPPET ADJUSTING	1	
3-2	12852H33000H000	NUT	1	
4	09181H12180H000	GASKET, VALVE INSIDE SPRING	2	
5	12861H35000H000	SHAFT, VALVE ROCKER ARM	2	
6	12862H35000H000	RETAINER, ROCKER ARM SHAFT	1	
7	02122-0616A-000	SCREW	1	
8	12911H36030H000	VALVE, INTAKE	1	
9	12912H36000H000	VALVE, EXHAUST	1	
10	09181-19261-000	GASKET, VALVE OUTSIDE SPRING	2	
11	12922H35000H000	SPRING, VALVE OUTER	2	
12	12921H35000H000	SPRING, VALVE INNER	2	
13	12931H35000H000	RETAINER VALVE SPRING	2	
14	12932H33000H000	VALVE NIP	4	
15	12741H35000H000	SPROCKET, CAMSHAFT	1	
16	01500-0610A-000	BOLT	2	
17	09448H24001H000	SPRING, TORSION	2	

Fig. 8

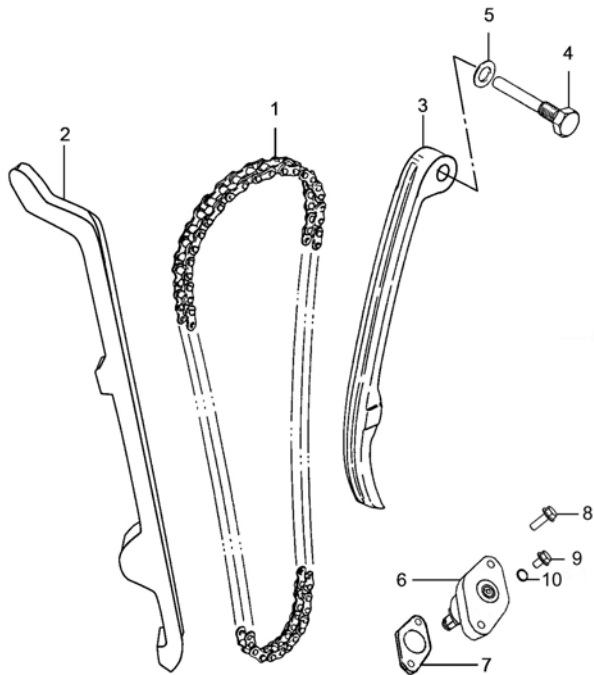

Fig.8 CAM CHAIN (P07-S080-0008)

REF. No.	PART No.	DESCRIPTION	Q'TY	REMARKS
1	12760H35020H000	CHAIN COMP, CAMSHAFT DRIVE	1	
2	12771H35000H000	GUIDE, CAM CHAIN	1	
3	12811H35001H000	TENSIONER, CAM CHAIN	1	
4	09135H08004H000	BOLT	1	
5	09160H08011H000	WASHER	1	
6	12830H35060H000	ADJUSTER ASSY, TENSIONER	1	
7	12837H35000H000	GASKET, TENSIONER ADJUSTER	1	
8	01547-0620A-000	BOLT	2	
9	09128H06010H000	BOLT, HEX WITH CROSS RECESS	1	
10	11142H35000H000	O RING	1	

2



Fig. 9

2

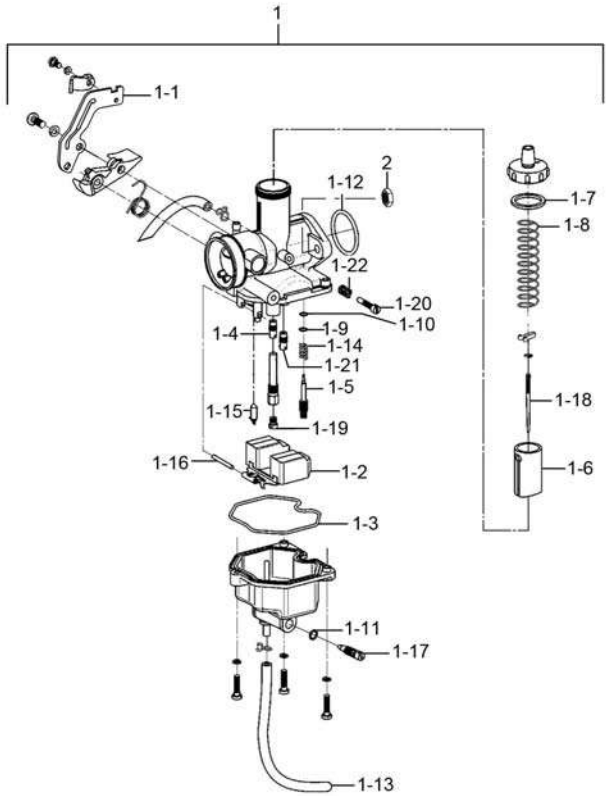

Fig.9 CARBURETOR (P07-S090-0022)

REF. No.	PART No.	DESCRIPTION	Q' TY	REMARKS
1	13200H12A30H000	CARBURETOR ASSY	1	
1-1	13270H12000H000	BRACKET	1	
1-2	13232H05200H000	FLOAT COMP.	1	
1-3	13222H05200H000	FLOAT CHAMBER GASKET	1	
1-4	13241H11300H000	NEEDLE JET	1	
1-5	13261H05200H000	PILOT ADJUST SCREW	1	
1-6	13551H12100H000	PISTON VALVE	1	
1-7	13255H05200H000	TOP GASKET	1	
1-8	13573H12100H000	COMPRESSION SPRING	1	
1-9	13262H05200H000	WASHER	1	
1-10	13295H21D20H000	O RING	1	
1-11	13225H05200H000	O RING	1	
1-12	13213H05200H000	O RING	1	
1-13	13223H05200H000	HOSE	1	
1-14	13264H05200H000	SPRING	1	
1-15	13234H05200H000	NEEDLE VALVE ASSY.	1	
1-16	13231H05200H000	PIN	1	
1-17	13226H05200H000	DRAIN SCREW	1	
1-18	13383H12000H000	JET NEEDLE	1	
1-19	09491H20070H000	JET, MAIN	1	
1-20	13263H05200H000	SPRING SCREW	1	
1-21	09492H12100H000	PILOT JET	1	
1-22	13266H05200H000	COMPRESSION SPRING	1	
2	08310-0006A-000	NUT	2	



Fig. 10

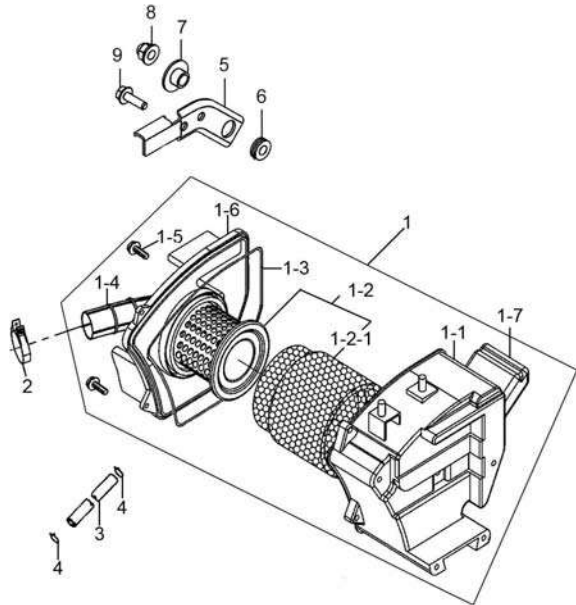

Fig.10 AIR CLEANER (P07-S100-0009)

REF. No.	PART No.	DESCRIPTION	Q'TY	REMARKS
1	13700H11A10H000	CLEANER ASSY, AIR	1	
1-1	13720H11700H000	CASE COMP, AIR CLNR	1	
1-2	13780H12910H000	FILTER ASSY, AIR CLEANER	1	
1-2-1	13781H12910H000	FILTER, AIR CLEANER	1	
1-3	13722H12600H000	GASKET, AIR CLNR CAP	1	
1-4	13881H12600H000	TUBE, OUTLET	1	
1-5	09136-05040-000	SCREW, THROTTLE CASE	4	
1-6	13741H12610H000	CAP, AIR CLNR	1	
1-7	13891H12600H000	TUBE, AIR FILTER INLET	1	
2	09402-46203-000	CLAMP	1	
3	13851H12600H000	TUBE, BREATHER	1	
4	09401-15101-000	CLIP, 2ND AIR CLNR HOSE	2	
5	41291H12600H000	PLATE, AIR CLEANER	1	
6	09320-08051-000	CUSHION, MUF COVER	1	
7	09180H06207H000	BUSH	1	
8	08313-2006B-000	DOMED CAP NUT	1	
9	01550-0612A-000	BOLT	2	

2



Fig. 11

2

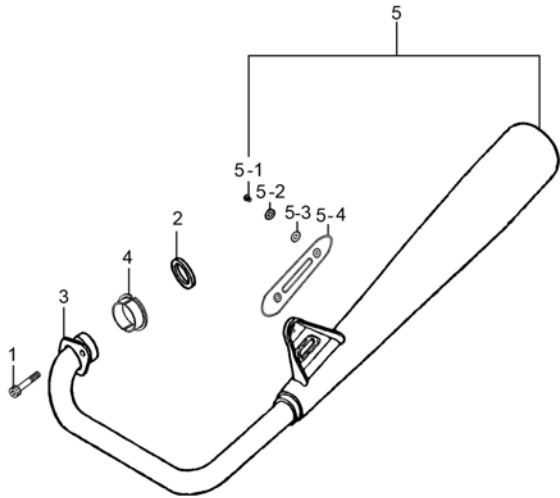

**Fig.11 MUFFLER (P07-S110-0013)**

REF. No.	PART No.	DESCRIPTION	Q' TY	REMARKS
1	07130-0825A-000	BOLT	2	
2	14181H11200H000	CUSHION	1	
3	14182H12900H000	FLANGE, EXHAUST PIPE	1	
4	14181H16000H000	SNAP RING, EXHAUST PIPE	2	
5	14305H11C60H000	MUFFLER COMP	1	
5-1	09139-06078-000	SCREW	2	
5-2	09160-06094-000	WASHER, PLAIN	2	
5-3	09168-06122-000	WASHER, MUF COVER INSULATOR	2	
5-4	14791H12900H000	COVER, MUF BODY	1	

Fig. 12

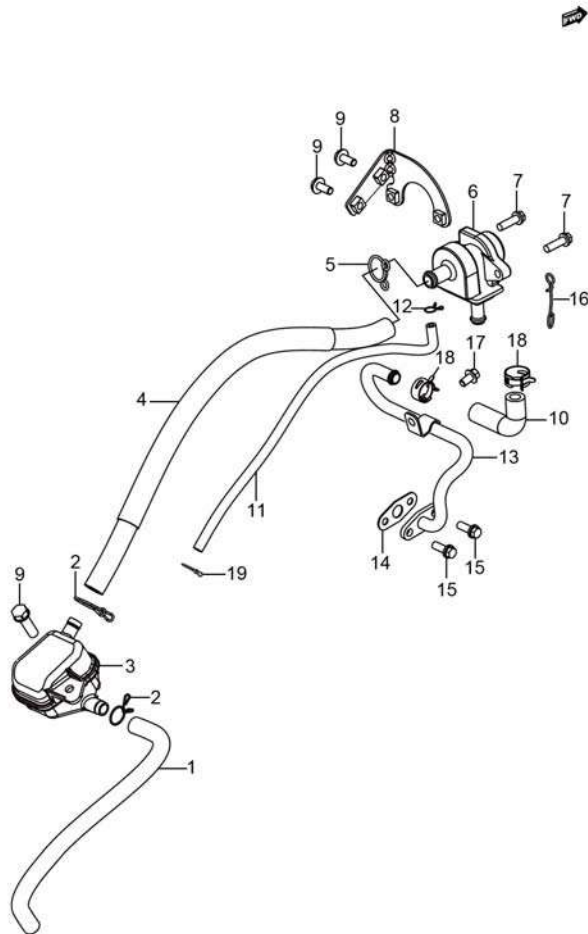

Fig.12 2ND AIR VAVLE (P07-S120-0014)

REF. No.	PART No.	DESCRIPTION	Q'TY	REMARKS
1	18711H12E20H000	HOSE, 2ND AIR CLNR	1	
2	09401-13409-000	CLIP, 2ND AIR VALVE HOSE	2	
3	18700H12E00H000	CLEANER ASSY, 2ND AIR	1	
4	18712H12E11H000	HOSE, 2ND AIR CLNR	1	
5	09401-15101-000	CLIP, 2ND AIR CLNR HOSE	1	
6	18450H12E60H000	VALVE ASSY, 2ND AIR	1	
7	01550-0620A-000	BOLTS, HEXAGON HEAD FLANGE	2	
8	18610H12E00H000	BRACKET COMP, 2ND AIR VALVE	1	
9	01550-0616A-000	BOLT	3	
10	18461H12E00H000	HOSE, 2ND AIR VALVE	1	
11	18463H2E002H000	HOSE, 2ND AIR VALVE VACUUM	1	
12	09401H07201H000	CLIP	1	
13	18410H12E10H000	PIPE COMP, 2ND AIR	1	
14	18441H50100H000	SEAL, 2ND AIR HOSE	1	
15	01547-0616A-000	BOLT	2	
16	18442-26H01-000	GUIDE, 2ND AIR VALVE HOSE	1	
17	01547-0612A-000	HEXAGON BOLT WITH FLANGE	1	
18	09401-15404-000	CLIP, FUEL HOSE	2	
19	09401-06101-000	CLIP	1	

2

Fig. 13



2

Fig.13 OIL PUMP (P07-S130-0003)

REF. No.	PART No.	DESCRIPTION	Q' TY	REMARKS
1	16400H35020H000	PUMP ASSY, ENG OIL	1	
2	02122-0630A-000	CROSS RECESSED HEAD SCREW	2	
3	09280H35000H000	O-RING	2	

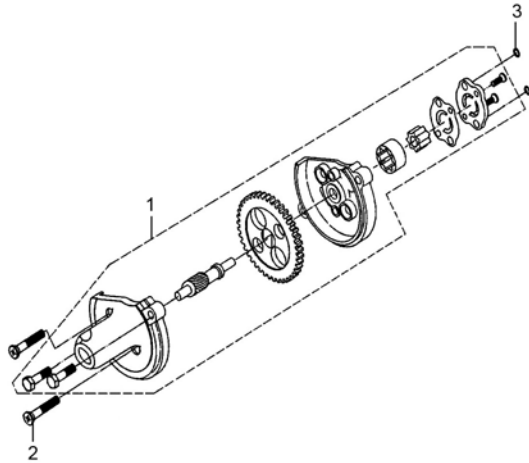

Fig. 14

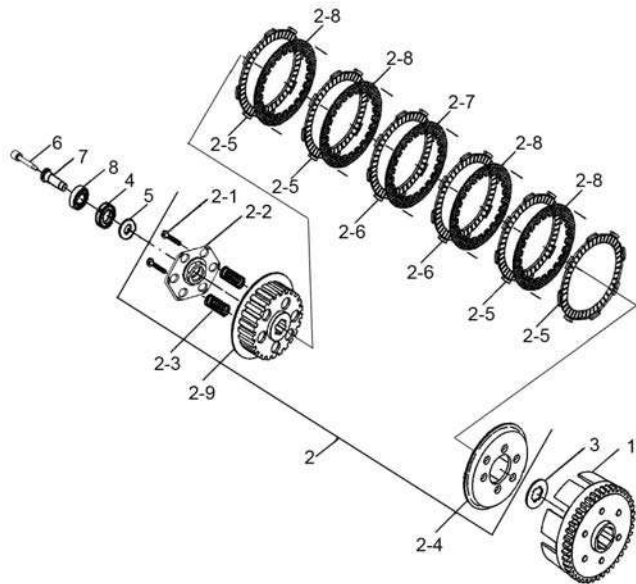

Fig.14 CLUTCH (P07-S140-0006)

REF. No.	PART No.	DESCRIPTION	Q' TY	REMARKS
1	21210H36000H000	HUB COMP, PRIMARY DRIVE	1	
2	21410H36040H000	HUB COMP, CLUTCH SLEEVE	1	
2-1	01550-0520A-000	BOLTS, HEXAGON HEAD FLANGE	6	
2-2	21471H36000H000	PLATE, CLUTCH PUSH ROD	1	
2-3	21413H36000H000	SPRING, CLUTCH	6	
2-4	21462H36000H000	DISC, CLUTCH PRESSURE	1	
2-5	21441H33010H000	PLATE, CLUTCH DRIVE	4	
2-6	21441H33020H000	PLATE, CLUTCH DRIVE	2	
2-7	21451H33000H000	PLATE, CLUTCH DRIVEN	1	
2-8	21451H36000H000	PLATE, CLUTCH DRIVEN	4	
2-9	21411H36000H000	HUB, CLUTCH SLEEVE	1	
3	21481H33000H000	WASHER	1	
4	21346H33000H000	NUT, LOCK	1	
5	16581H33000H000	WASHER	1	
6	23131H3D000H000	POLE, CLUTCH PUSH	1	
7	23121H3D000H000	PIECE, CLUTCH PUSH	1	
8	09262H17001H000	BEARING, CLUTCH	1	

2



Fig. 15

2

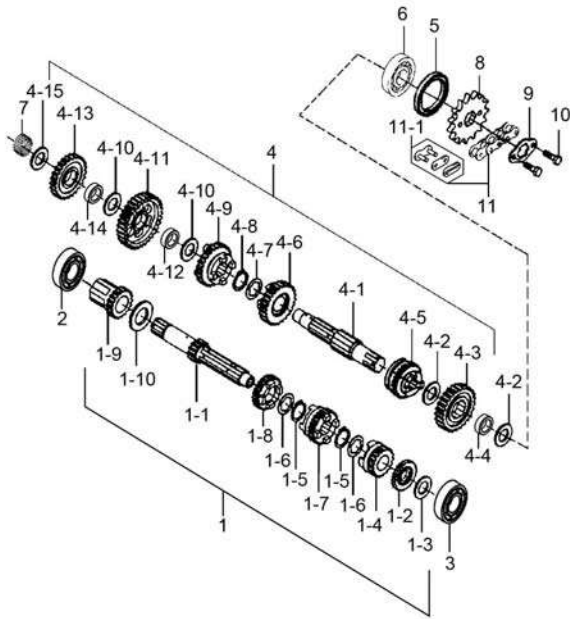

Fig.15 TRANSMISSION (P07-S150-0009)

REF. No.	PART No.	DESCRIPTION	Q' TY	REMARKS
1	24102H3F000H000	SHAFT ASSY, COUNTER	1	
1-1	24121H3F000H000	SHAFT, COUNTER	1	
1-2	24221H35000H000	GEAR, 2ND DRIVE	1	
1-3	08211-15251-000	WASHER, 1ST DRIVEN GEAR, R THR	1	
1-4	24251H36000H000	GEAR, 5TH DRIVE	1	
1-5	08331-31209-000	CIRCLIP	2	
1-6	24232H33000H000	WASHER	2	
1-7	24241H35000H000	GEAR, 4TH DRIVE	1	
1-8	24231H35000H000	GEAR, 3RD DRIVE	1	
1-9	24210H3F000H000	GEAR COMP, DRIVE	1	
1-10	09181H20270H000	WASHER	1	
2	08110-60060-000	BEARING	1	
3	09262H15010H000	BEARING	1	
4	24103H36031H000	SHAFT ASSY, DRIVE	1	
4-1	24131H36031H000	SHAFT, DRIVE	1	
4-2	08211-20271-000	WASHER	2	
4-3	24321H35000H000	2ND SPEED GREA, COUNTERSHAFT (32 TEETH)	1	
4-4	24322H3E000H000	BUSH, 2ND DRIVEN GEAR	1	
4-5	24351H36000H000	GEAR, 5TH DRIVEN	1	
4-6	24341H35000H000	GEAR, 4TH DRIVEN	1	
4-7	24232H33000H000	WASHER	1	
4-8	08331-31209-000	CIRCLIP	1	
4-9	24331H35000H000	GEAR, 3TH DRIVEN	1	
4-10	09181H17240H000	WASHER	2	
4-11	24311H36000H000	GEAR, 1ST DRIVEN	1	
4-12	24314H35000H000	BUSH, 1ST DRIVEN GEAR	1	
4-13	26261H3E000H000	GEAR, KICK STARTER IDLE	1	

Fig. 15

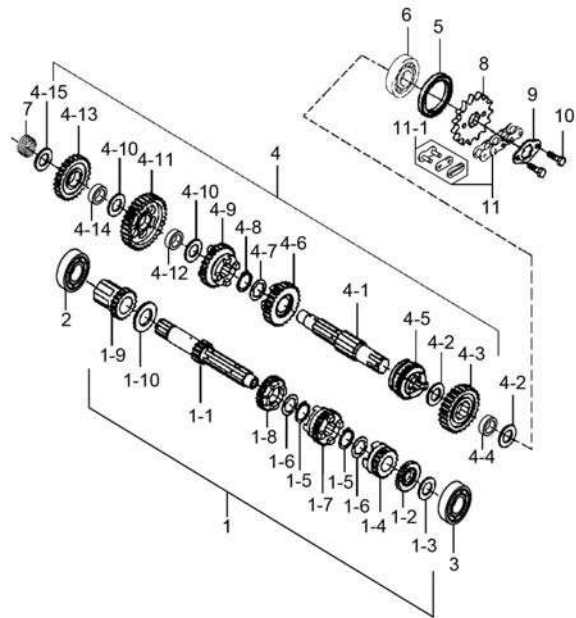

Fig.15 TRANSMISSION (P07-S150-0009)

REF. No.	PART No.	DESCRIPTION	Q'TY	REMARKS
4-14	26263H35000H000	BUSH, KICK STARTER IDLE GEAR	1	
4-15	08211-15301-000	WASHER	1	
5	09283H20059H000	OIL SEAL	1	
6	08110-62040-000	BEARING, DRIVE SHAFT	1	
7	09263H15002H000	BEARING, NEEDLE	1	
8	27511H36010H000	SPROCKET, ENGINE	1	
9	27521H33010H000	WASHER	1	
10	07130-0610A-000	HEXAGON SOCKET HEAD CAP SCREW	2	
11	27600H2A000H108	CHAIN ASSY, DRIVE	1	
11-1	27620H2A000H000	JOINT SET, CHAIN	1	

2



Fig. 16

2

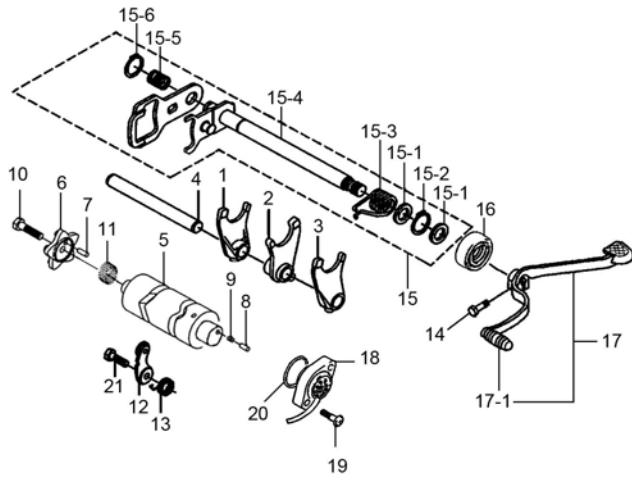

Fig.16 GEAR SHIFTING (P07-S160-0007)

REF. No.	PART No.	DESCRIPTION	Q' TY	REMARKS
1	25211H35000H000	FORK, GEAR SHIFT, R	1	
2	25231H35000H000	FORK, GEAR SHIFT, MIDDLE	1	
3	25241H35000H000	FORK, GEAR SHIFT, L	1	
4	25411H35000H000	SHAFT, GEAR SHIFT FORK	1	
5	25311H36010H000	CAM, GEAR SHIFT	1	
6	25381H35000H000	PLATE, SHIFT CAM STOPPER	1	
7	04221-04109-000	PIN	1	
8	25314H36000H000	PIN, CAM SHIFT	1	
9	09440H04010H000	SPRING, COMPRESSION	1	
10	09128H06001H000	BOLT, HEX WITH CROSS RECESS	1	
11	09263H23000H000	BEARING, NEEDLE	1	
12	25350H35000H000	STOPPER COMP, GEAR SHIFT CAM	1	
13	09448H18001H000	SPRING, TORSION	1	
14	01500-0820A-000	BOLT	1	
15	25500H36020H000	SHAFT ASSY, GEAR SHIFT	1	
15-1	09181H16200H000	WASHER	2	
15-2	08331-31149-000	CIRCLIP, KICK SHAFT	1	
15-3	25518H35000H000	SPRING, SHIFT SHAFT RETURN	1	
15-4	25510H36020H000	SHAFT COMP, GEAR SHIFT	1	
15-5	09440H15002H000	SPRING, COMPRESSION	1	
15-6	08331-31129-000	CIRCLIP	1	
16	09283H14001H000	OIL SEAL	1	
17	25600H11A10H000	LEVER ASSY, GEAR SHIFT	1	
17-1	25652H16500H000	RUBBER, GEAR SHIFT PEDAL	1	
18	37720H22500H000	BASE ASSY, GEAR SHIFT TERM	1	
19	02112-0418A-000	CROSS RECESSED HEAD SCREW	2	
20	09280H19001H000	O-RING	1	
21	01500-0620A-000	BOLT	1	



Fig.17

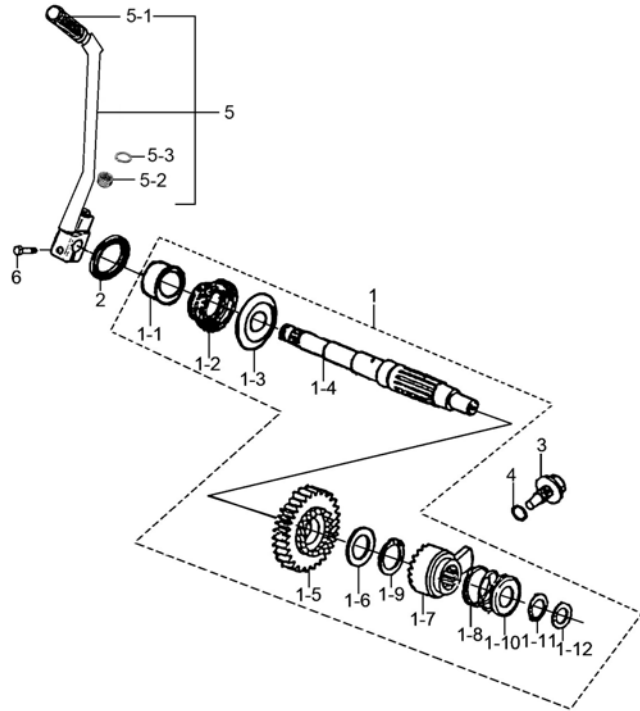

Fig.17 KICK STARTER (P07-S165-0006)

REF. No.	PART No.	DESCRIPTION	Q'TY	REMARKS
1	26210H3E000H000	SHAFT COMP, KICK STARTER	1	
1-1	26221H35000H000	GUIDE, KICK STARTER SHAFT SPRIN	1	
1-2	09448H48003H000	SPRING, TORSION	1	
1-3	26222H35000H000	HOLDER, KICK STARTER SHAFT SPRI	1	
1-4	26211H3E000H000	SHAFT, KICK STARTER	1	
1-5	26241H35000H000	GEAR, KICK STARTER DRIVE	1	
1-6	09181H20001H000	SHIM	1	
1-7	26251H35000H000	RATCHET WHEEL	1	
1-8	26226H36000H000	SPRING, RELEASE	1	
1-9	09380H19001H000	RING, SNAP	1	
1-10	26225H35000H000	SEAT, RELEASE SPRING	1	
1-11	09380H15001H000	RING, SNAP	1	
1-12	09181H12004H000	SHIM	1	
2	09283H16001H000	OIL SEAL	1	
3	09135H12001H000	BOLT	1	
4	09280H11001H000	O-RING	1	
5	26300H12E10H000	LEVER ASSY, KICK STARTER	1	
5-1	26352-01000-000	RUBBER, KICK STARTER LEVER	1	
5-2	09440-05003-000	SPRING, KICK STARTER LEVER	1	
5-3	08331-3115A-000	CIRCLIP	1	
6	01500-0825A-000	BOLTS, HEXAGON HEAD	1	

2



Fig. 18

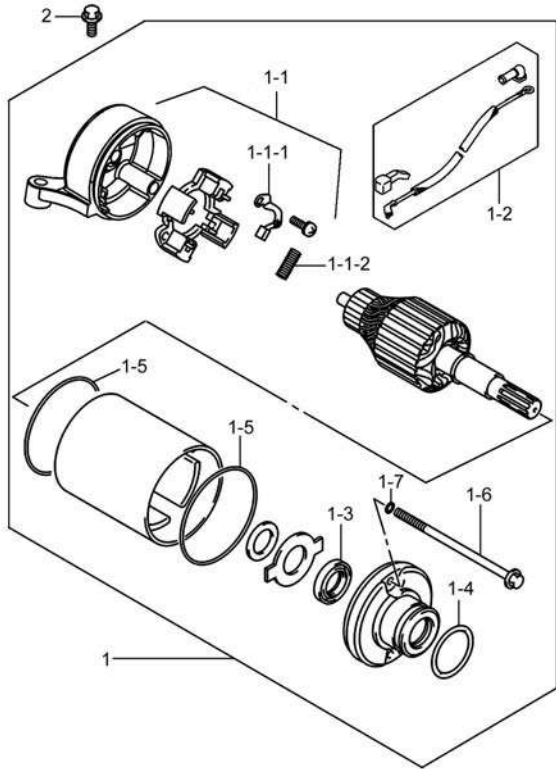

Fig.18 STARTING MOTOR (P07-S170-0005)

REF. No.	PART No.	DESCRIPTION	Q' TY	REMARKS
1	31100H36031H000	MOTOR ASSY, STARTING	1	
1-1	31175H36000H000	FRAME ASSY	1	
1-1-1	31133H2A200H000	BRUSH, STARTER MOTOR, MINUS	1	
1-1-2	31135H36000H000	SPRING, STARTER MOTOR BRUSH	2	
1-2	33810H36000H000	WIRE, STARTER MOTOR	1	
1-3	31153H22500H000	OIL SEAL, STARTER MOTOR	1	
1-4	09280H33000H000	O RING	1	
1-5	31264H36000H000	O-RING	2	
1-6	31281H36000H000	BOLT	2	
1-7	31156H36000H000	O-RING	2	
2	01547-0630A-000	BOLT	2	

3

Fig. 19

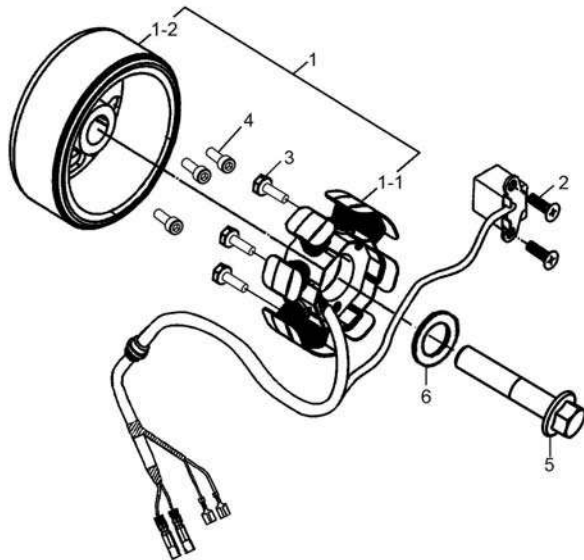

Fig.19 MAGNETO (P07-S180-0005)

REF. No.	PART No.	DESCRIPTION	Q' TY	REMARKS
1	32100H35081H000	MAGNETO ASSY	1	
1-1	32101H35081H000	STATOR ASSY	1	
1-2	32102H35080H000	ROTOR ASSY	1	
2	02112-0516A-000	CROSS RECESSED HEAD SCREW	2	
3	01500-0525A-000	BOLTS, HEXAGON HEAD	3	
4	32491H33010H000	BOLT, MAGNETO ROTOR	3	
5	32111H33000H000	BOLT	1	
6	32113H35000H000	WASHER	1	

3



Fig. 20

**Fig.20 BATTERY (P07-S190-0018)**

REF. No.	PART No.	DESCRIPTION	Q' TY	REMARKS
1	33611H12911H000	BATTERY	1	
2	33651H11A00H000	BAND, BATTERY	1	
3	33860H11A00H000	WIRE, BATTERY MINUS LEAD	1	
4	41560H11A00H000	BRACKET ASSY, BATTERY	1	
5	41540H11A01H000	HOLDER ASSY, BATTERY	1	
6	01550-0625A-000	BOLT	1	
7	01550-0612B-000	BOLT	3	
8	09407H15401H000	CLAMP, WIRING HARNESS	1	
9	PROTECTOR, BATTERY	1		
10	33680H12920H000	HOSE, BATTERY EXHAUST	1	

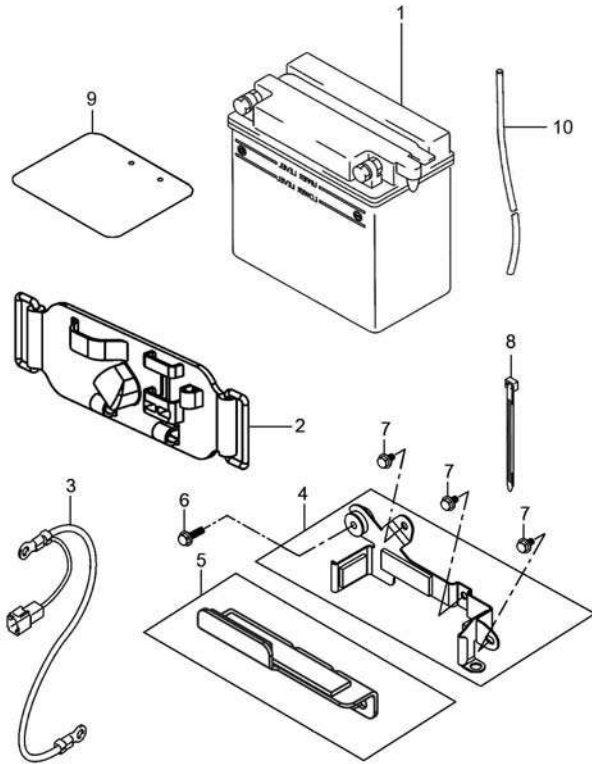

3



Fig. 21

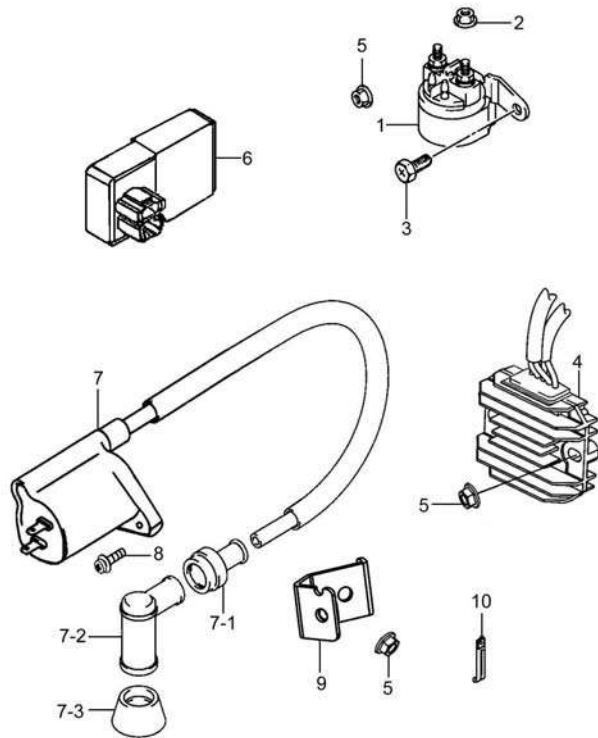

Fig.21 ELECTRICAL (P07-S200-0017)

REF. No.	PART No.	DESCRIPTION	Q'TY	REMARKS
1	31800-49110-000	RELAY ASSY, STARTING MOTOR	1	
2	08361-3506A-000	NUT	2	
3	09128-06004-000	SCREW, STG MOT RLY	1	
4	32800H05550H000	RECTIFIER ASSY	1	
5	08316-1006B-000	NUT	4	
6	32900H12960H000	IGNITER ASSY	1	
7	33410H05510H000	COIL ASSY, IGNITION	1	
7-1	33542-38B00-000	SEAL, HIGH TENSION CORD	1	
7-2	33510-04H10-000	CAP, SPARK PLUG	1	
7-3	33541-38210-000	SEAL, SPARK PLUG	1	
8	02112-1520A-000	CROSS RECESSED HEAD SCREW	1	
9	41894H11700HN00	BRACKET COMP, IGNITION COIL	1	
10	36651H12500H000	CLAMP	1	

3



Fig. 22

Fig.22 SPEEDOMETER (P07-S210-0016)

3

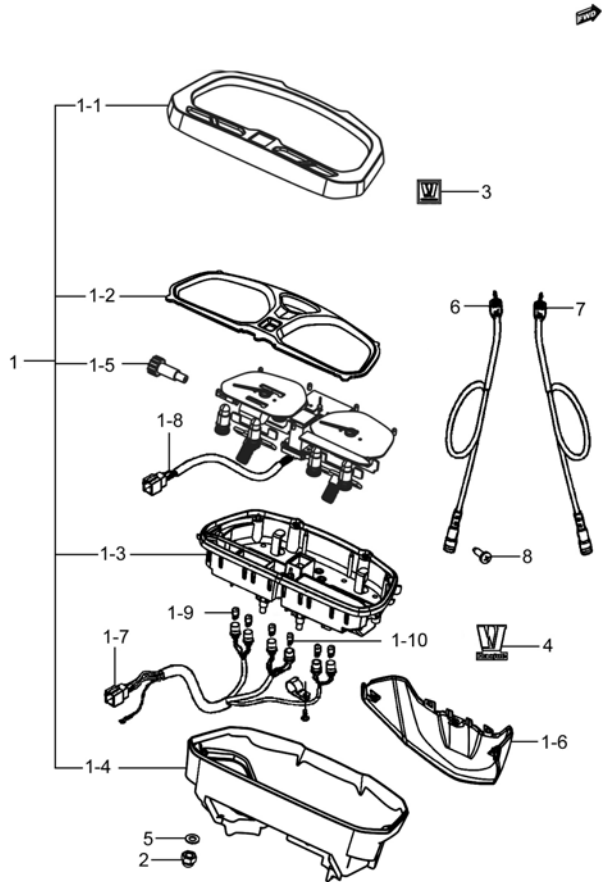

REF. No.	PART No.	DESCRIPTION	Q' TY	REMARKS
1	34100H11A11H000	SPEEDOMETER ASSY	1	
1-1	34150H11A10H000	HOOD, SPEEDOMETER	1	
1-2	34113H11A10H000	PLATE, SPEEDOMETER	1	
1-3	34111H11A11H000	CASE, SPEEDOMETER, LOWER	1	
1-4	34152H11A10H000	LOW CASE, SPEEDOMETER	1	
1-5	34980H11A10H000	KNOB	1	
1-6	34156H11A10H000	ORNAMENT PIECE, SP	1	
1-7	34173H11A10H000	WIRE HARNESS, SPEEDOMETER	1	
1-8	34174H11A10H000	WIER HARNESS, METER NO. 2	1	
1-9	09471-12196-000	BULB, CUNIFORM LAMP HOLDER	3	T10 12V 3W
1-10	09471-12077-000	BULB	3	T10 12V 2W
2	08310-0006A-000	NUT	3	
3	68171H22500H000	EMBLEM, LOGO	1	
4	68170H12E00H000	LOGO	1	
5	09160-06129-000	WASHER, PLAIN	3	
6	34910H12E00H000	CABLE ASSY, SPEEDOMETER	1	
7	34940H11A00H000	CABLE ASSY, TACHOMETER	1	
8	02132-05257-000	SCREW	1	

Fig. 23

Fig.23 HEADLAMP (P07-S220-0010)

REF. No.	PART No.	DESCRIPTION	Q'TY	REMARKS
1	35100H11A11H000	HEADLAMP ASSY	1	
1-1	35121H11A11H000	UNIT, HEADLAMP	1	
1-1-1	35124H11A10H000	LENS, HEADLAMP	1	
1-2	09471H12001H000	BULB (12V, 35/35W)	1	HS1 12V 35/35W
1-3	09471-12081-000	BULB, POSITION LAMP	1	12V 5W
1-4	35171H11A10H000	CORD, HEADLAMP	1	
1-5	35174H2A110H000	BOOT, HEADLAMP HOUSING	1	

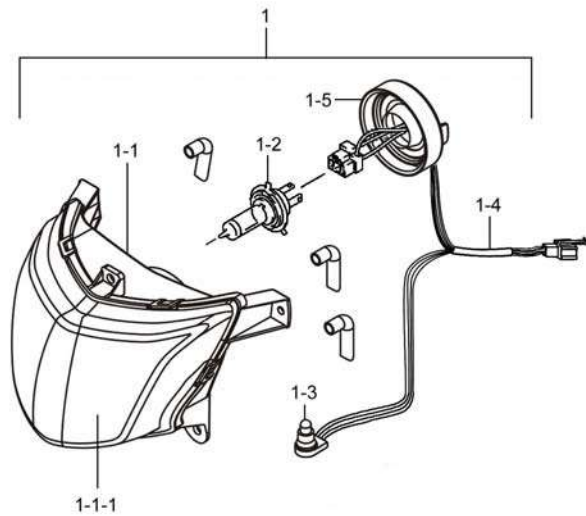

3



Fig. 24

Fig.24 TURN SIGNAL LAMP (P07-S230-0009)

REF. No.	PART No.	DESCRIPTION	Q' TY	REMARKS
1	35601H11A01H000	LAMP ASSY, FRONT TURNSIGNAL, R	1	
1-1	35610H11A00H000	UNIT, FRONT TURNSIGNAL, R	1	
1-2	09471-12177-000	BULB (12V 10W)	1	12V 10W
2	35602H11A01H000	LAMP ASSY, FRONT TURNSIGNAL, L	1	
2-1	35630H11A00H000	UNIT, FRONT TURNSIGNAL, L	1	
2-2	09471-12177-000	BULB (12V 10W)	1	12V 10W
3	35603H11A01H000	LAMP ASSY, REAR TURNSIGNAL, R	1	
3-1	35630H11A00H000	UNIT, FRONT TURNSIGNAL, L	1	
3-2	09471-12177-000	BULB (12V 10W)	1	12V 10W
4	35604H11A01H000	LAMP ASSY, REAR TURNSIGNAL, L	1	
4-1	35610H11A00H000	UNIT, FRONT TURNSIGNAL, R	1	
4-2	09471-12177-000	BULB (12V 10W)	1	12V 10W
5	08316-1010A-000	NUT	4	
6	35616H11A01H000	PLATE, TURNSIGNAL	2	
7	38610H11222H000	RELAY ASSY, TURNSIGNAL	1	

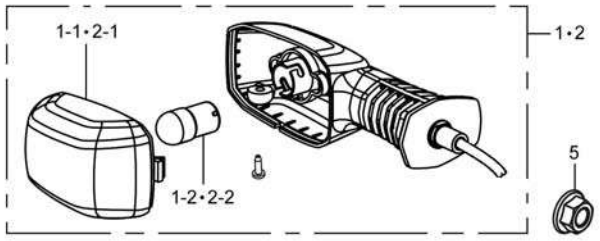
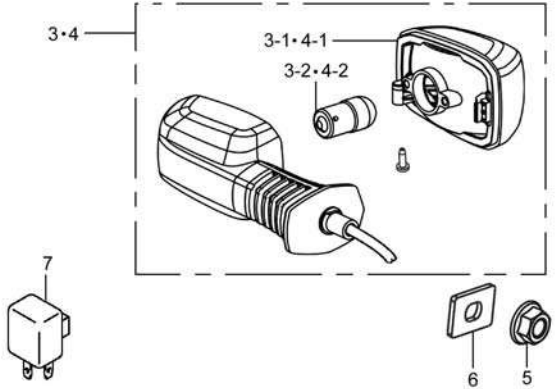

3





Fig. 25

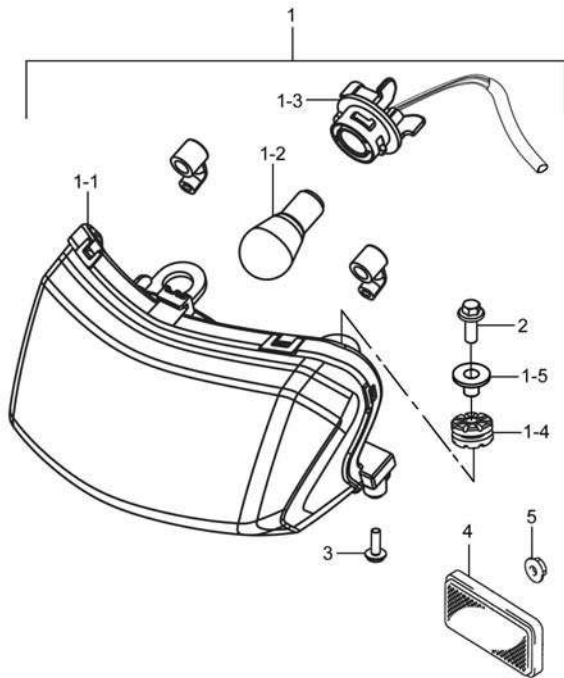

Fig.25 REAR COMBINATION LAMP (P07-S240-0008)

REF. No.	PART No.	DESCRIPTION	Q'TY	REMARKS
1	35710H11A00H000	LAMP ASSY, REAR COMB	1	
1-1	35720H11A00H000	UNIT, REAR COMB	1	
1-2	09471-12128-000	BULB (12V, 21/5W)	1	12V 21/5W
1-3	35718H11A00H000	CORD COMP, REAR COMB	1	
1-4	35764H11A00H000	CUSHION, REAR COMB, INNER	1	
1-5	35766H11A00H000	SPACER, REAR COMB LAMP	1	
2	01550-0625A-000	BOLT	2	
3	09136H04003H000	SCREW WITH WASHER	2	
4	35970-04H01-000	REFLEX REFLECTOR ASSY, REAR	1	
5	08316-1005A-000	HEXAGON FLANGE NUT	1	

3

Fig. 26

Fig.26 WIRING HARNESS (P07-S250-0020)

REF. No.	PART No.	DESCRIPTION	Q' TY	REMARKS
1	36610H11A21H000	HARNESS WIRING	1	
2	36619H12901H000	CLAMP, WIRING HARNESS	1	
3	09407-12402-000	CLAMP, WIRING HARNESS	3	L=128
4	09407-14403-000	CLAMP, FUEL HOSE	3	L=125
5	36651H12610H000	CLAMP, WIRING HARNESS	2	L=155
6	36651H12500H000	CLAMP	1	L=74.5
7	44256H12600H000	SEPARATOR	2	
8	36651-45F40-000	CLAMP, WIRING HARNESS	2	L=155
9	03541-0512B-000	SCREW	1	
10	09404-06429-000	CLAMP, CARB OVFL HOSE	1	L=60
11	09481-15001-000	FUSE	1	
12	37100H11A10H000	LOCK ASSY, STEERING	1	
13	37101H11200H000	BOLT	2	
14	37740H12601H000	SWITCH ASSY, STOP LAMP	1	
15	38500H12601H000	HORN ASSY	1	
16	01550-0612B-000	BOLT	1	
17	37011H11AB0H000	LOCK SET	1	

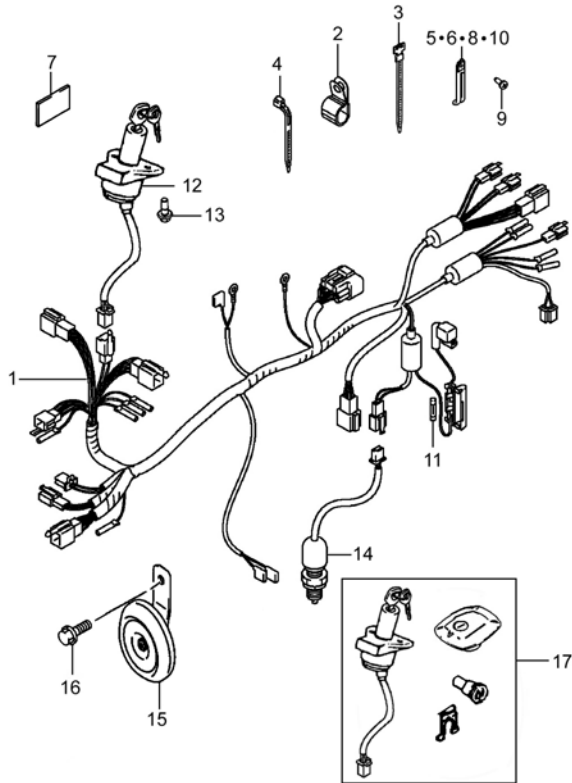

3

Fig. 27

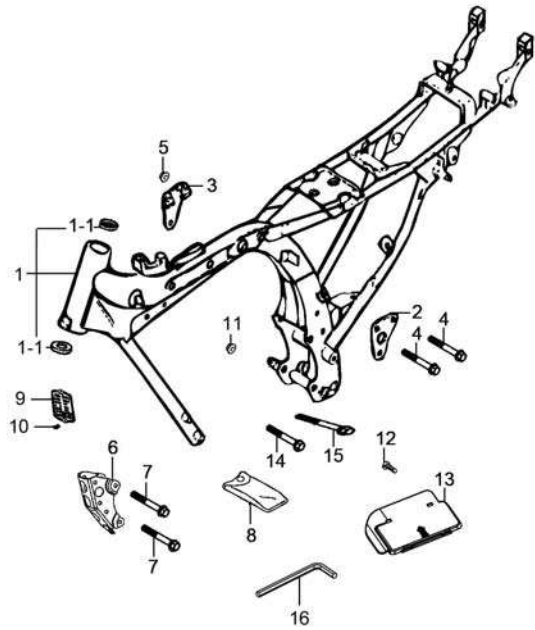

Fig.27 FRAME (P07-S260-0042)

REF. No.	PART No.	DESCRIPTION	Q' TY	REMARKS
1	41101H11Y70H000	FRAME SET	1	
1-1	51611H11200H000	INSIDE RACE	2	
2	41993H16100H000	UPPER BRACKET, ENGINE LH	1	
3	41991H16100H000	UPPER BRACKET, ENGINE RH	1	
4	41919-45F00-000	BOLT, ENG MTG LOWER	2	
5	08319-3108A-000	NUT	4	
6	41992H12920H000	BRKT, ENG MTG LOWER	1	
7	09103H08013H000	BOLT, HEXAGON	2	
8	09800H11201H000	TOOL SET	1	
9	68311H30180H000	PLATE, L ICENSE	1	
10	68389-45F00-000	RIVET	2	
11	08319-3110A-000	NUT	2	
12	02112-1520B-000	CROSS RECESSED HEAD SCREW	2	
13	47432H11700H000	CAP, TOOL BOX	1	
14	09103H08015H000	BOLT, HEXAGON	2	
15	09103H10003H000	BOLT, HEXAGON	2	
16	09816-05700-000	SPANNER	1	

4



Fig. 28

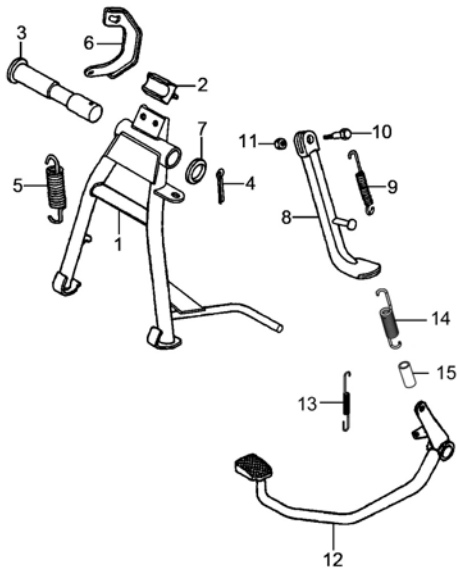

Fig.28 STAND (P07-S270-0009)

REF. No.	PART No.	DESCRIPTION	Q' TY	REMARKS
1	42100H12600H000	STAND COMP, CENTER	1	
2	42278H12900H000	STOPPER, CENTER STAND	2	
3	42211H11200H000	AXLE	1	
4	04111-2525A-000	COTTER PIN	1	
5	09443H18101H000	SPRING, TENSION	1	
6	42112H12900H000	SPING PLATE, CENTER STAND	1	
7	43142H11200H000	WASHER	1	
8	42310H12900H000	STAND COMP, PROP	1	
9	42321H11200H000	SPRING	1	
10	42322H11201H000	BOLT, SIDE STAND	1	
11	09159H10097H000	NUT	1	
12	43110H12910H000	PEDAL COMP, BRAKE	1	
13	09443H05002H000	SPRING, TENSION	1	
14	09443H14004H000	SPRING, TENSION	1	
15	43142H21302H000	HOSE, RUBBER	1	

4



Fig. 29

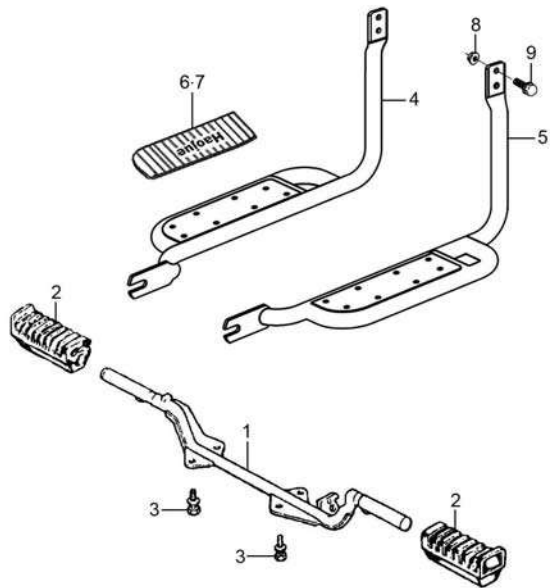

Fig.29 FOOTREST (P07-S280-0023)

REF. No.	PART No.	DESCRIPTION	Q' TY	REMARKS
1	43510H12E01H000	BAR COMP, FRONT FOOTREST	1	
2	43551H12E00H000	RUBBER, FRONT FOOTREST	2	
3	01580-0820B-000	HEXAGON HEAD BOLT	4	
4	43610H11A20H000	BOARD COMP, PILLION FOOTREST, R	1	
5	43710H11A20H000	BOARD COMP, PILLION FOOTREST, L	1	
6	43618H12900H000	RUBBER, PILLION FOOTREST, R	1	
7	43718H12900H000	RUBBER, PILLION FOOTREST, L	1	
8	08319-3108A-000	NUT	4	
9	01580-0825B-000	HEXAGON HEAD BOLT	4	

4



Fig. 30

Fig.30 FUEL TANK (P07-S290-0031)

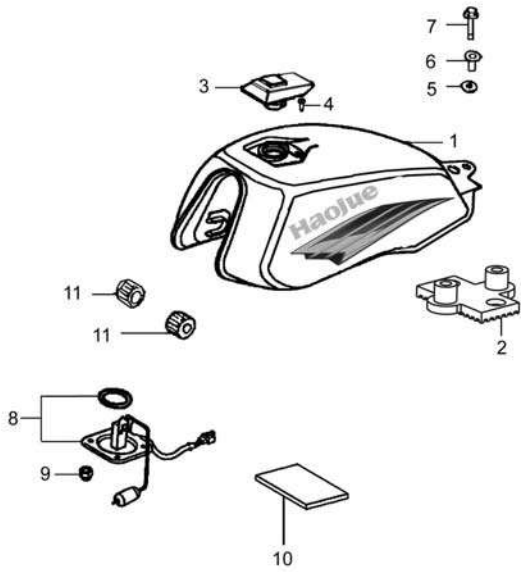

REF. No.	PART No.	DESCRIPTION	Q' TY	REMARKS
1	44011H11AMOHF01	FUEL TANK SET (RED)	1	
1	44011H11AMOHF02	FUEL TANK SET (BLACK)	1	
1	44011H11AMOHF03	FUEL TANK SET (BLUE)	1	
2	44542H11A00H000	CUSHION, FUEL TANK REAR LOWER	1	
3	44200H11A00H000	CAP ASSY, FUEL TANK FILLER	1	
4	02112-0406A-000	CROSS RECESSED HEAD SCREW	2	
5	09320H10022H000	CUSHION	2	
6	44544-45F10-000	SPACER, FUEL TANK, REAR	2	
7	09116-06084-000	BOLT, FUEL TANK REAR	2	
8	34810H11710H000	GAUGE ASSY, FUEL LEVEL SENDER	1	
9	08316-1006A-000	NUT	4	
10	44256H12600H000	SEPARATOR	2	
11	44541H11200H000	CUSHION, FRONT	2	

4

Fig. 31

Fig.31 FUEL COCK (P07-S300-0008)

REF. No.	PART No.	DESCRIPTION	Q' TY	REMARKS
1	44300H11A00H000	COCK ASSY, FUEL	1	
2	44420H11700H000	HOSE COMP, FUEL	1	
3	09401-08414-000	CLIP	2	
4	44428H12900H000	GUIDE, FUEL HOSE	1	

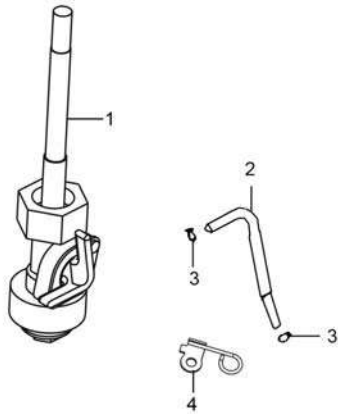

4



Fig. 32

Fig.32 FRAME COVER (P07-S310-0041)

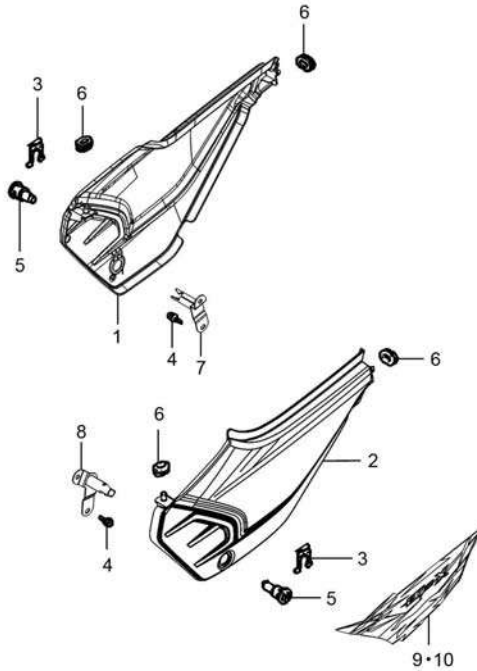

REF. No.	PART No.	DESCRIPTION	Q' TY	REMARKS
1	47111H11A00HA39	COVER, FRAME, R (RED/MATTE BLACK)	1	
1	47111H11A00HA28	COVER, FRAME, R (BLACK/MATTE BLACK)	1	
1	47111H11A00HA30	COVER, FRAME, R (BLUE/MATTE BLACK)	1	
2	47211H11A00HA39	COVER, FRAME, L (RED/MATTE BLACK)	1	
2	47211H11A00HA28	COVER, FRAME, L (BLACK/MATTE BLACK)	1	
2	47211H11A00HA30	COVER, FRAME, L (BLUE/MATTE BLACK)	1	
3	47641H11200H000	SPRING	2	
4	02112-1612B-000	SCREWS, CROSS RECESSED HEAD	4	
5	47600H11202H000	LOCK ASSY, SIDE COVER	2	
6	47312H02100H000	RUBBER CUSHION	4	
7	47320H11A00H000	BUTTON ASSY, SIDE COVER LOCK, R	1	
8	47330H11700H000	BUTTON ASSY, SIDE COVER LOCK, L	1	
9	68130H11A20HR94	TAPE SET, FRAME COVER STRIPE, R (R94)	1	
9	68130H11A20HR96	TAPE SET, FRAME COVER STRIPE, R (R96)	1	
9	68130H11A20HR95	TAPE SET, FRAME COVER STRIPE, R (R95)	1	
10	68140H11A20HR94	TAPE SET, FRAME COVER STRIPE, L (R94)	1	
10	68140H11A20HR96	TAPE SET, FRAME COVER STRIPE, L (R96)	1	
10	68140H11A20HR95	TAPE SET, FRAME COVER STRIPE, L (R95)	1	

4



Fig. 33

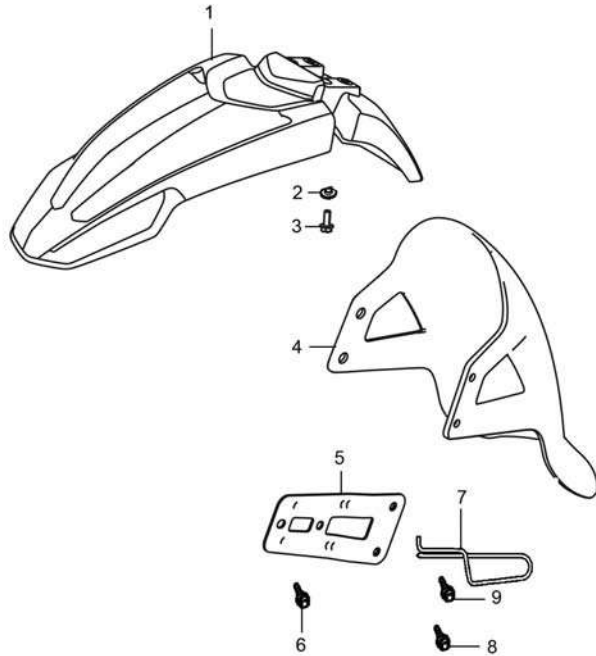

Fig.33 FRONT FENDER (P07-S320-0013)

REF. No.	PART No.	DESCRIPTION	Q' TY	REMARKS
1	53111H11A00H000	FENDER, FRONT	1	
2	09169-06065-000	SPACER, BATTERY HOLDER	4	
3	09116-06167-000	BOLT WITH WASHER	4	
4	53211H11A00H000	FENDER, FRONT LOWER	1	
5	53112H11A00H000	BRACE, FRONT FENDER	2	
6	01580-0616B-000	BOLT	4	
7	58621H11A00H000	GUIDE, SPEEDOMETER CABLE	1	
8	01550-0616B-000	BOLT	2	
9	09111-06107-000	BOLT	2	

4



Fig. 34

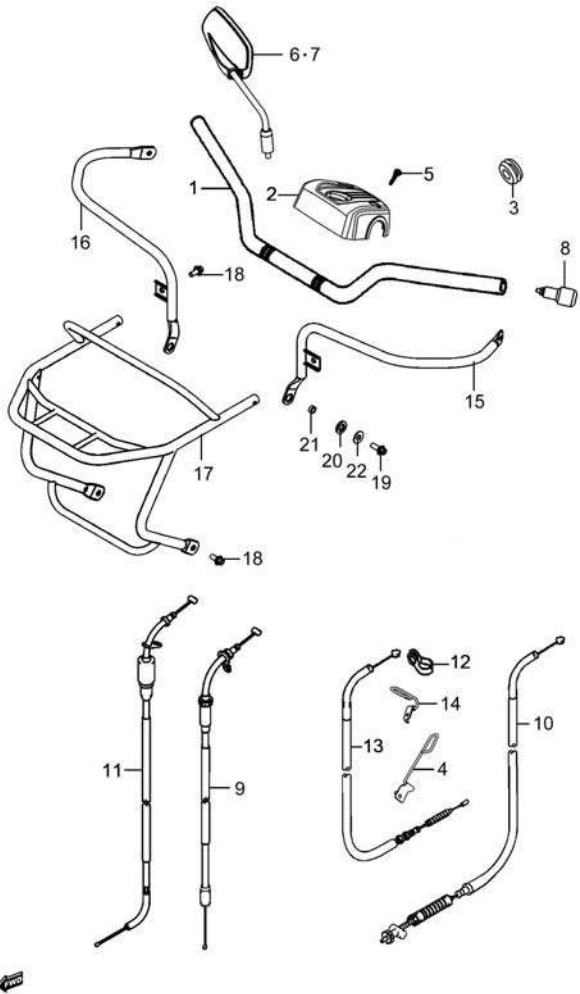

Fig.34 HANDLEBAR (P07-S330-0023)

REF. No.	PART No.	DESCRIPTION	Q' TY	REMARKS
1	56110H11A10H000	HANDLEBAR COMP	1	
2	56171H11A01H000	COVER, STEERING HEAD	1	
3	37157H12600H000	COVER, STEERING LOCK	1	
4	58620H11A10H000	GUIDE COMP, CLUTCH CABLE	1	
5	02142-0616B-000	SCREW	2	
6	56500H11260H000	MIRROR ASSY, REAR VIEW, R	1	
7	56600H11260H000	MIRROR ASSY, REAR VIEW, L	1	
8	56270H11A10H000	BALANCER ASSY, HANDLEBAR	2	
9	58300H11A11H000	CABLE ASSY, THROTTLE	1	
10	58100H11A11H000	CABLE ASSY, FRONT BRAKE	1	
11	58410H12910H000	CABLE COMP, STARTER	1	
12	34938H12600H000	CLAMP	1	
13	58200H11A20H000	CABLE ASSY, CLUTCH	1	
14	58620H11A00H000	GUIDE COMP, CLUTCH CABLE	1	
15	94280H11A00H000	BUMPER COMP, HANDLEBAR, L	1	
16	94270H11A00H000	BUMPER COMP, HANDLEBAR, R	1	
17	94260H11A00H000	BUMPER COMP, HEADLAMP	1	
18	01550-0816B-000	HEXAGON BOLT WITH FLANGE	4	
19	01550-0820B-000	HEXAGON BOLT WITH FLANGE	2	
20	09320H12007H000	CUSHION	2	
21	09180H08023H000	SPACER	2	
22	09160H08040H000	WASHER, PLAIN	2	

4

Fig. 35

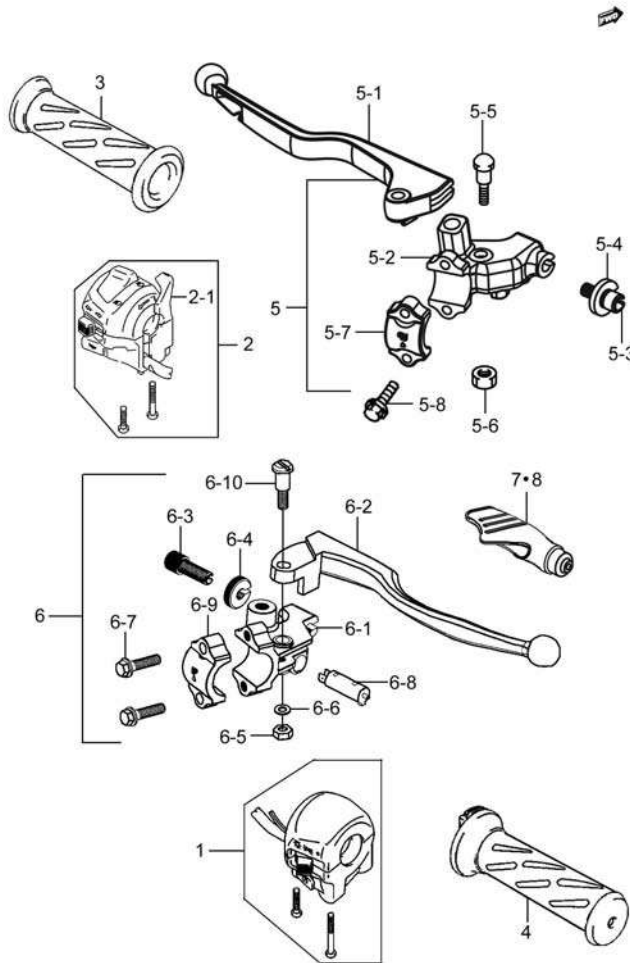

Fig.35 HANDLE SWITCH (P07-S340-0015)

REF. No.	PART No.	DESCRIPTION	Q'TY	REMARKS
1	37200H11A00H000	SWITCH ASSY, HANDLE, R	1	
2	37400H11A00H000	SWITCH ASSY, HANDLE, L	1	
2-1	37571H05503H000	LEVER, CHOKE	1	
3	57211-45FB0-000	GRIP, L	1	
4	57110-28G10-000	GRIP COMP THROTTLE	1	
5	57500-053D0-000	LEVER ASSY, CLUTCH	1	
5-1	57621-053C0-000	LEVER, CLUTCH	1	
5-2	57511-053B0-000	HOLDER, LEVER	1	
5-3	57441-45C00-000	ADJUSTER, CABLE	1	
5-4	57442-45C00-000	NUT, CABLE ADJUSTER	1	
5-5	57431-45C01-000	BOLT, LEVER	1	
5-6	08319-2106B-000	U-NUT	1	
5-7	57512-45F00-000	BRACKET	1	
5-8	01547-0620B-000	BOLT	2	
6	57300-36H10-000	LEVER ASSY, BRAKE	1	
6-1	57311-36H00-000	HOLDER, BRAKE LEVER	1	
6-2	57421-36H00-000	LEVER, BRAKE	1	
6-3	57441-45F00-000	ADJUSTER, WIRE	1	
6-4	57442-45F00-000	NUT, LOCK	1	
6-5	08310-0006A-000	NUT	1	
6-6	08321-0106B-000	SPRING LOCK WASHER	1	
6-7	01547-0620B-000	BOLT	2	
6-8	57460-45F00-000	SWITCH ASSY, FRONT BRAKE	1	
6-9	57512-45F00-000	BRACKET	1	
6-10	57431-36H00-000	BOLT, LEVER PIVOT	1	
7	57661-05300-000	COVER, CLUTCH LEVER	1	
8	57341-36H00-000	COVER, BRAKE LEVER	1	

4

Fig. 36

**Fig.36 REAR FENDER (P07-S350-0009)**

REF. No.	PART No.	DESCRIPTION	Q' TY	REMARKS
1	63112H11700H000	BODY, REAR FENDER FRONT	1	
2	63141H11200H000	SPACING	1	
3	01550-0620B-000	BOLT	1	
4	63119H11200H000	NUT	1	
5	63113H11A01H000	BODY, REAR FENDER, REAR	1	
6	01550-0620A-000	BOLTS, HEXAGON HEAD FLANGE	2	
7	35927-37G00-000	BRACKET, LICENSE PLATE	1	
8	08316-1006B-000	NUT	2	
9	36651-12F10-000	CLAMP	1	
10	09180H06025H000	SPACER	2	

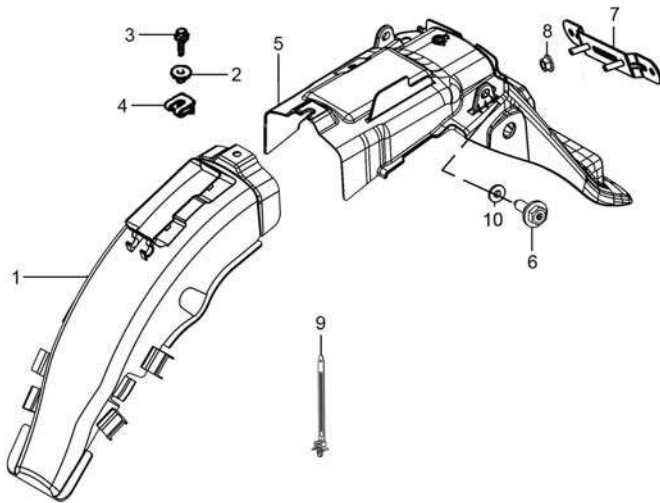

4

Fig. 37

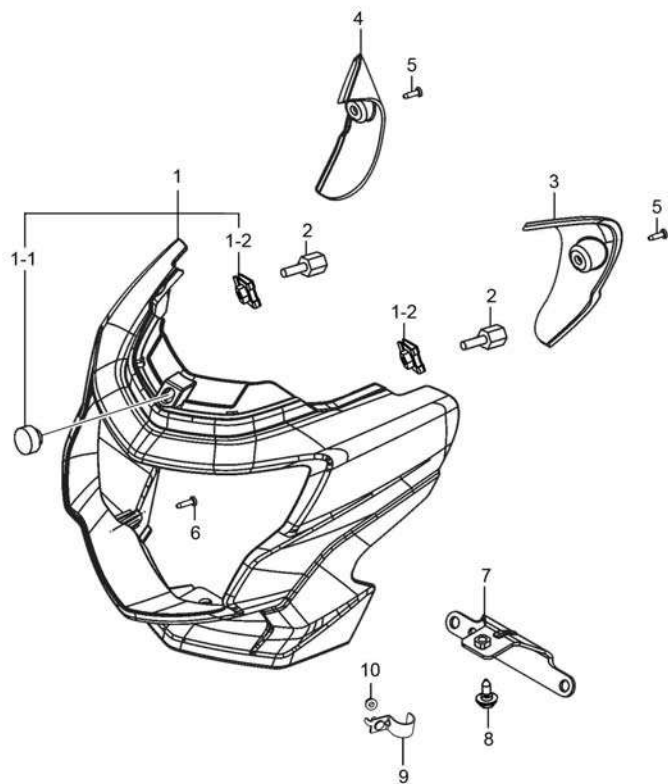

Fig.37 COWLING (P07-S360-0007)

REF. No.	PART No.	DESCRIPTION	Q'TY	REMARKS
1	94041H11A30HA39	COWLING SET (RED/MATTE BLACK)	1	
1	94041H11A30HA28	COWLING SET (BLACK/MATTE BLACK)	1	
1	94041H11A30HA30	COWLING SET (BLUE/MATTE BLACK)	1	
1-1	09321H09001H000	CUSHION	1	
1-2	94434H12E00H000	NUT, CTR COWL	2	
2	94577H12E00H000	BOLT, COWLING BRACKET	2	
3	94425H11A00H000	PANEL, SIDE, L	1	
4	94415H11A00H000	PANEL, SIDE, R	1	
5	02142-0510B-000	CROSS RECESSED HEAD SCREW	2	
6	35151-21J00-000	SCREW, HEADLAMP	3	
7	94550H11A00H000	BRACKET COMP, COWLING LOWER	1	
8	09111-06066-000	BOLT, FIXED FR FENDER	1	
9	36651H12E01H000	CLAMP, WIRING HARNESS	1	
10	08316-1006B-000	NUT	1	

4

Fig. 38

**Fig.38 LABEL (P07-S370-0033)**

REF. No.	PART No.	DESCRIPTION	Q' TY	REMARKS
1	68319-29F00-000	LABEL, WARNING SAFETY	1	
2	99011H11A80H000	MANUAL, OWNER'S	1	
3	68332H11210H000	LABEL, TIRE INFORMATION	1	

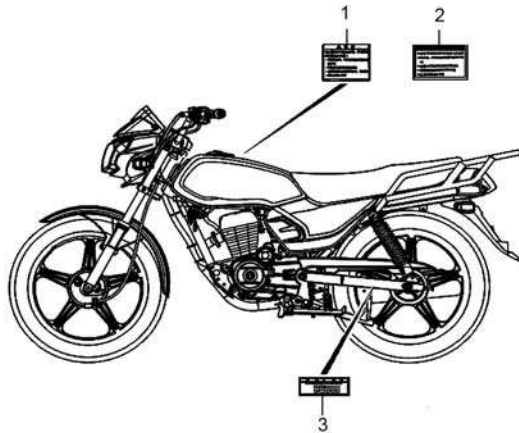

4

Fig. 39

**Fig.39 SEAT (P07-S380-0006)**

REF. No.	PART No.	DESCRIPTION	Q' TY	REMARKS
1	45100H11A01H000	SEAT ASSY	1	
1-1	45160H11A00H000	COVER COMP, SEAT	1	
2	08322-0108A-000	PLAIN WASHER	2	
3	07130-0816B-000	SCREWS, HEXAGON SOCKET HEAD CAP	2	

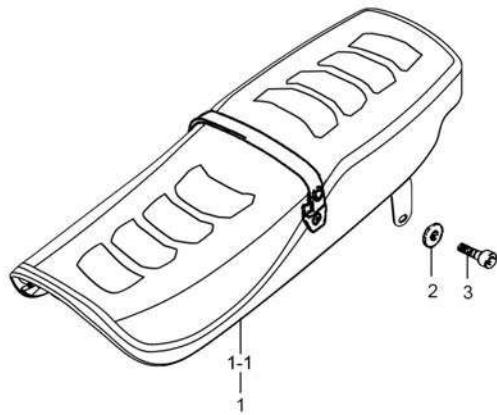

4



Fig. 40

Fig.40 COVER,SEAT TAIL (P07-S390-0022)

REF. No.	PART No.	DESCRIPTION	Q' TY	REMARKS
1	45511H11A01HA39	COVER, SEAT TAIL, R (RED/MATTE BLACK)	1	
1	45511H11A01HA28	COVER, SEAT TAIL, R (BLACK/MATTE BLACK)	1	
1	45511H11A01HA30	COVER, SEAT TAIL, R (BLUE/MATTE BLACK)	1	
2	45513H11A00H104	COVER, SEAT TAIL, CTR (RED)	1	
2	45513H11A00H541	COVER, SEAT TAIL, CTR (BLACK)	1	
2	45513H11A00H608	COVER, SEAT TAIL, CTR (BLUE)	1	
3	45512H11A01HA39	COVER, SEAT TAIL, L (RED/MATTE BLACK)	1	
3	45512H11A01HA28	COVER, SEAT TAIL, L (BLACK/MATTE BLACK)	1	
3	45512H11A01HA30	COVER, SEAT TAIL, L (BLUE/MATTE BLACK)	1	
4	45518H11A00H000	INSERT, TAIL COVER, R	1	
5	45519H11A00H000	INSERT, TAIL COVER, L	1	
6	63121H11A00H000	BRACKET, REAR COMB	1	
7	94434H12E00H000	NUT, CTR COWL	2	
8	35765H12900H000	CUSHION, REAR COMB LAMP	1	
9	01550-0616B-000	BOLT	2	
10	03541-0408B-000	CROSS RECESSED HEAD TAPPING SCREW	4	

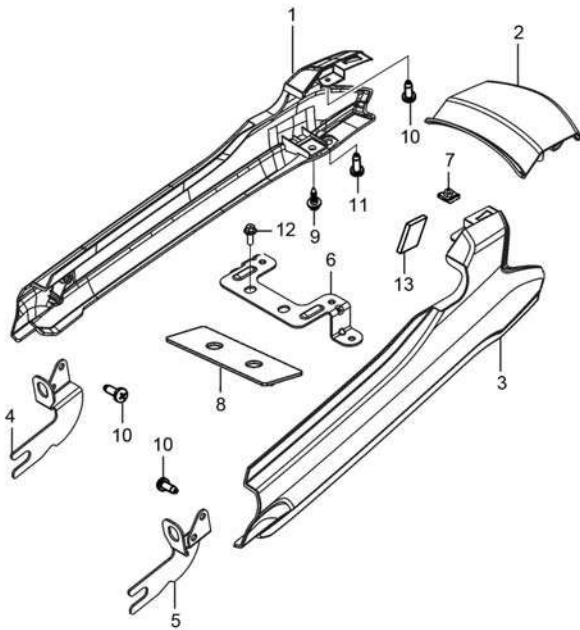

4



Fig. 40

Fig.40 COVER,SEAT TAIL (P07-S390-0022)

REF. No.	PART No.	DESCRIPTION	Q' TY	REMARKS
11	03541-0412B-000	SCREW	2	
12	09111-06061-000	SCREW, FRONT FENDER	2	
13	56314-20E00-000	GASKET NO. 2, HEADLAMP COVER	6	

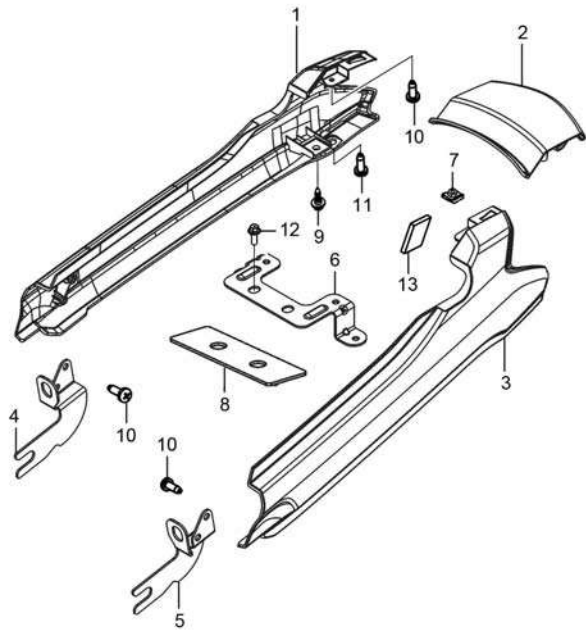

4

Fig. 41

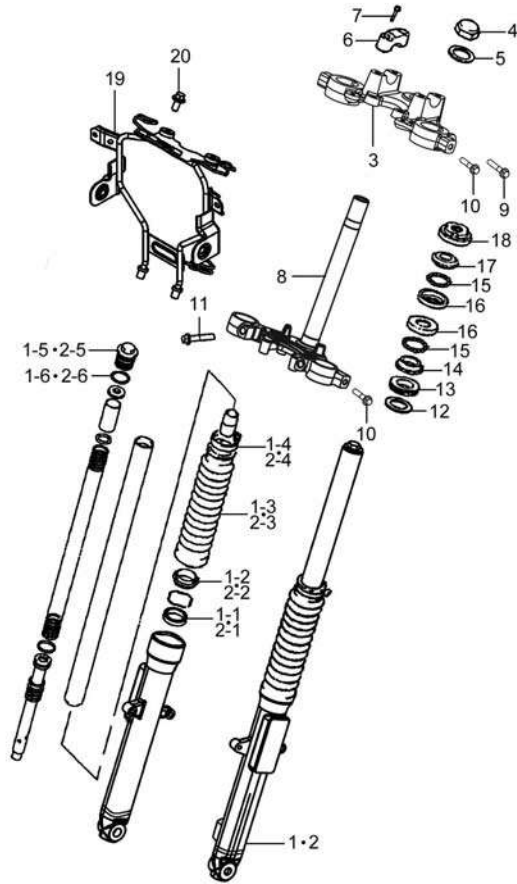

Fig.41 STEERING STEM (P07-S400-0019)

REF. No.	PART No.	DESCRIPTION	Q' TY	REMARKS
1	51103H11A90H000	DAMPER ASSY, FRONT FORK, R	1	
1-1	51153H12710H000	OIL SEAL	1	
1-2	51173H12710H000	SEAL, DUST	1	
1-3	51571H11A00H000	BOOT	1	
1-4	51575H11A00H000	BAND, BOOT	1	
1-5	51189H11A00H000	CAP	1	
1-6	51117-45F40-000	O RING	1	
2	51104H11A90H000	DAMPER ASSY, FRONT FORK, L	1	
2-1	51153H12710H000	OIL SEAL	1	
2-2	51173H12710H000	SEAL, DUST	1	
2-3	51571H11A00H000	BOOT	1	
2-4	51575H11A00H000	BAND, BOOT	1	
2-5	51189H11A00H000	CAP	1	
2-6	51117-45F40-000	O RING	1	
3	51311H11A00H000	BRACKET, UPPER	1	
4	51353H11200H000	NUT	1	
5	51356H11200H000	GASKET	1	
6	56211H12600H000	HOLDER, HANDLE UPPER	2	
7	01550-0830B-000	HEXAGON BOLT WITH FLANGE	4	
8	51410H11A00H000	BRACKET COMP, UNDER	1	
9	01550-0835B-000	BOLT, HEXAGON HEAD FLANGE	2	
10	01550-0812B-000	BOLT	4	
11	01570-0840A-000	HEXAGON HEAD BOLT	2	
12	51625H11200H000	GASKET	1	
13	51626H11200H000	CUSHION	1	
14	51621H11200H000	RICE STEERING, OUT LOWER	1	
15	06111-06004-000	BALL, STEERING, UPPER	42	
16	51611H11200H000	INSIDE RACE	2	
17	51622H11200H000	RACE STEERING, OUT UPPER	1	

4

Fig. 41

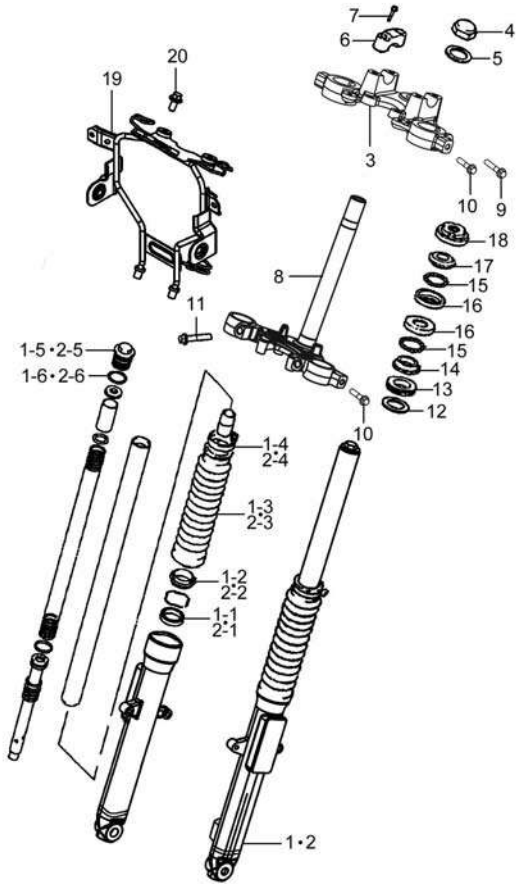

Fig.41 STEERING STEM (P07-S400-0019)

REF. No.	PART No.	DESCRIPTION	Q' TY	REMARKS
18	51630H11200H000	NUT	1	
19	94500H11A00H000	BRACKET ASSY, COWLING	1	
20	01550-0625A-000	BOLT	2	

4

Fig. 42

Fig.42 FRONT WHEEL (P07-S410-0037)

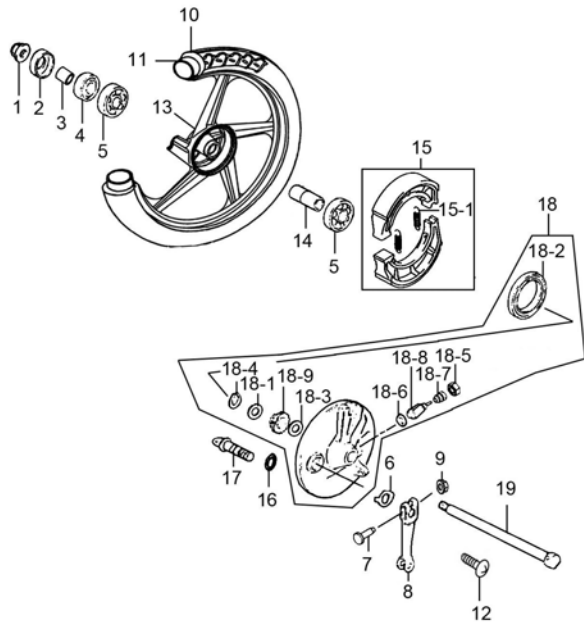

REF. No.	PART No.	DESCRIPTION	Q' TY	REMARKS
1	08319-3112A-000	U-NUT	1	
2	54892-45F00-000	COVER, FRONT HUB DUST SEAL	1	
3	54741H2A000H000	SPACER, FRONT AXLE, R	1	
4	54742-45F00-000	SEAL, FRONT HUB	1	
5	08133-63017-000	BEARING, FRONT HUB	2	
6	54492H11201H000	PLATE, FR BK LINING INDICATOR	1	
7	01550-0633A-000	BOLT, HEXAGON HEAD FLANGE	1	
8	54451H11200H000	LEVER, BRAKE CAM	1	
9	08316-1006A-000	NUT	1	
10	55100H11A00H000	TIRE SET, FR	1	
11	55200-45F00-000	TUBE ASSY, WHEEL INNER	1	
12	02132-0516A-000	SCREW	1	
13	54110H11A10H801	WHEEL COMP, FRONT (SILVER)	1	
14	54750H11200H000	SPACER	1	
15	54400H45Y20H000	SHOE COMP, BRAKE	1	
15-1	55421H11200H000	SPRING, BRAKE SHOE	2	
16	09280-14003-000	O-RING, REAR BRAKE CAM	1	
17	54441H12B00H000	CAM, FRONT BRAKE	1	
18	54200H12930H000	PANEL ASSY, FRONT BRAKE	1	
18-1	54613H11200H000	WASHER	1	
18-2	54616H11200H000	OIL SEAL	1	
18-3	54614H11200H000	WASHER	1	
18-4	08331-31208-000	CIRCLIP	1	
18-5	54626H11200H000	OIL SEAL	1	
18-6	54623H11200H000	THRUST WASHER	2	
18-7	54632H12930H000	BUSH, SPEEDOMETER PINION	1	
18-8	54621H12930H000	PINION, SPEEDOMETER	1	
18-9	54610H12900H000	DRIVER COMP, SPEEDOMETER GEAR	1	
19	54711H50000H000	AXLE, FRONT	1	

4

Fig. 43

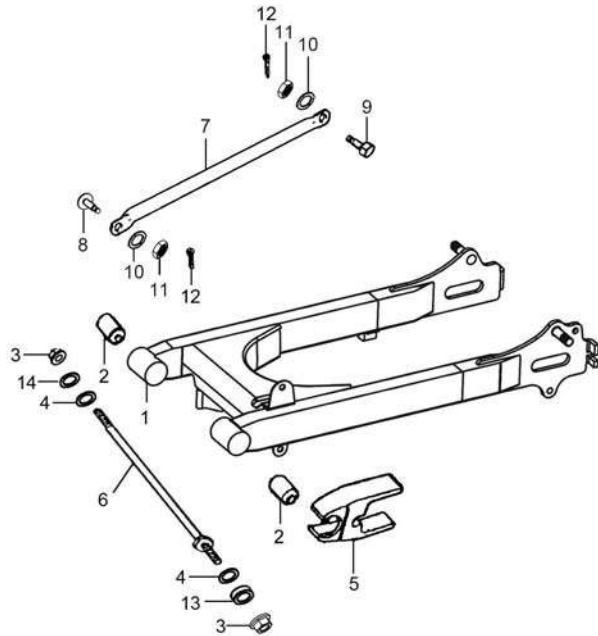

Fig.43 REAR SWINGING ARM (P07-S440-0029)

REF. No.	PART No.	DESCRIPTION	Q' TY	REMARKS
1	61100H12801H000	SWINGINGARM COMP, REAR	1	
2	61200H11200H000	BUFFER	2	
3	08319-3112A-000	U-NUT	2	
4	09160-12073-000	LOCK WASHER, LH	2	
5	61273H11700H000	BUFFER, CHAIN TOUCH DEFENSE	1	
6	61211H11700H000	SHAFT, RR SWG ARM PIVOT	1	
7	64311H11700H000	TORQUE LINK, REAR	1	
8	09111-08012-000	BOLT, REAR TORQUELINK FRONT	1	
9	09111-08013-000	BOLT, REAR TORQUELINK REAR	1	
10	09162-08008-000	LOCK WASHER, RR TORQUELINK	2	
11	09140H08001H000	NUT	2	
12	04111-2020A-000	COTTER PIN	2	
13	09180H12007H000	SPACER	1	
14	09160H13009H000	WASHER	1	

4



Fig. 44

**Fig.44 REARSHOCK ABSORBER (P07-S450-0015)**

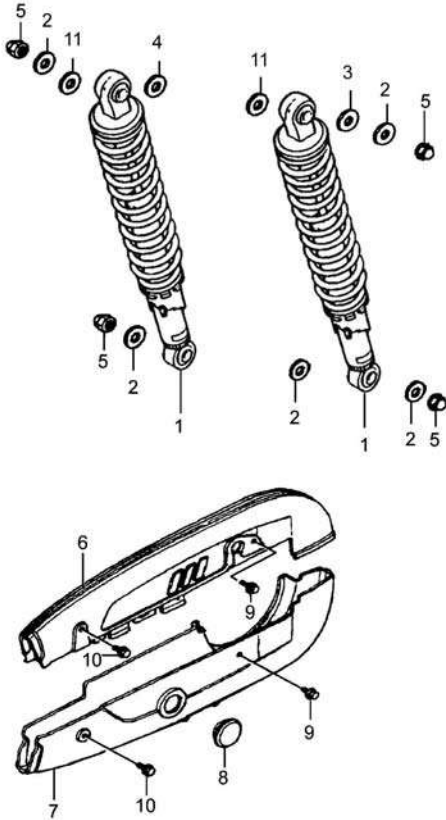

REF. No.	PART No.	DESCRIPTION	Q' TY	REMARKS
1	62100H11220H000	ABSORBER ASSY, REAR SHOCK	2	
2	09160H10001H000	WASHER, PLAIN	5	
3	09160H12009H000	WASHER, PLAIN	1	
4	09160H12006H000	WASHER, PLAIN	1	
5	09145H10003H000	NUT, CAP	4	
6	61310H12902H000	CASE COMP, CHAIN UPPER	1	
7	61320H12902H000	CASE COMP, CHAIN LOWER	1	
8	09250H34001H000	CAP	1	
9	01560-0608B-000	HEXAGON HEAD BOLT	2	
10	01550-0612B-000	BOLT	2	
11	09180H12013H000	SPACER	2	

4

Fig. 45

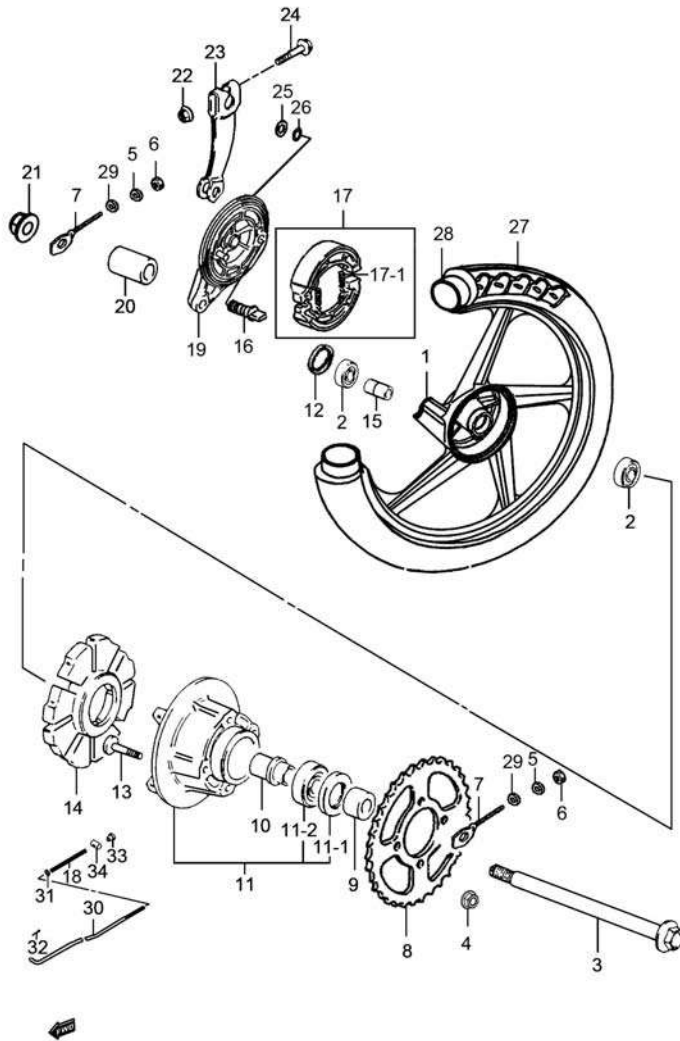

Fig.45 REAR WHEEL (P07-S460-0063)

REF. No.	PART No.	DESCRIPTION	Q'TY	REMARKS
1	64150H11A10H801	WHEEL COMP, REAR (SILVER)	1	
2	08124-63027-000	BALL BEARING	2	
3	64711H12800H000	AXLE, REAR	1	
4	08319-3108A-000	NUT	4	
5	08321-0108A-000	SPRING LOCK WASHER	2	
6	08310-0008A-000	HEXAGON NUT	2	
7	61410H12901H000	ADJUSTER COMP, CHAIN	2	
8	64511H11A00H000	SPROCKET, REAR	1	
9	64733H11A00H000	RETAINER, REAR SPROCKET DRUM	1	
10	64614H11A00H000	BUSH, RR SPROCKET DRUM	1	
11	64610H11A00H000	DRUM COMP, RR SPROCKET MOUNTING	1	
11-1	64612H11200H000	OIL SEAL	1	
11-2	08123-60047-000	BALL BEARING	1	
12	64653H11A00H000	O-RING, REAR WHEEL	1	
13	64541H12800H000	BOLT, REAR SPROCKET	4	
14	64651H11A00H000	ABSORBER, REAR HUB SHOCK	4	
15	64916H11A00H000	SPACER, REAR HUB	1	
16	64441H12B00H000	CAM, REAR BRAKE	1	
17	54400H11Y31H000	SHOE COMP, BRAKE	1	
17-1	55421H11200H000	SPRING, BRAKE SHOE	2	
18	09440H09007H000	SPRING, COMPRESSION	1	
19	64210H11000H000	PANEL COMP, REAR BRAKE	1	
20	09180H15014H000	SPACER	1	
21	08319-3114A-000	U-NUT	1	
22	08316-1006A-000	NUT	1	
23	64451H12B00H000	LEVER, REAR BRAKE CAM	1	
24	01550-0633A-000	BOLT, HEXAGON HEAD FLANGE	1	
25	64492H11200H000	FINGER, REAR BRAKE	1	
26	09280-14003-000	O-RING, REAR BRAKE CAM	1	

4

Fig. 45

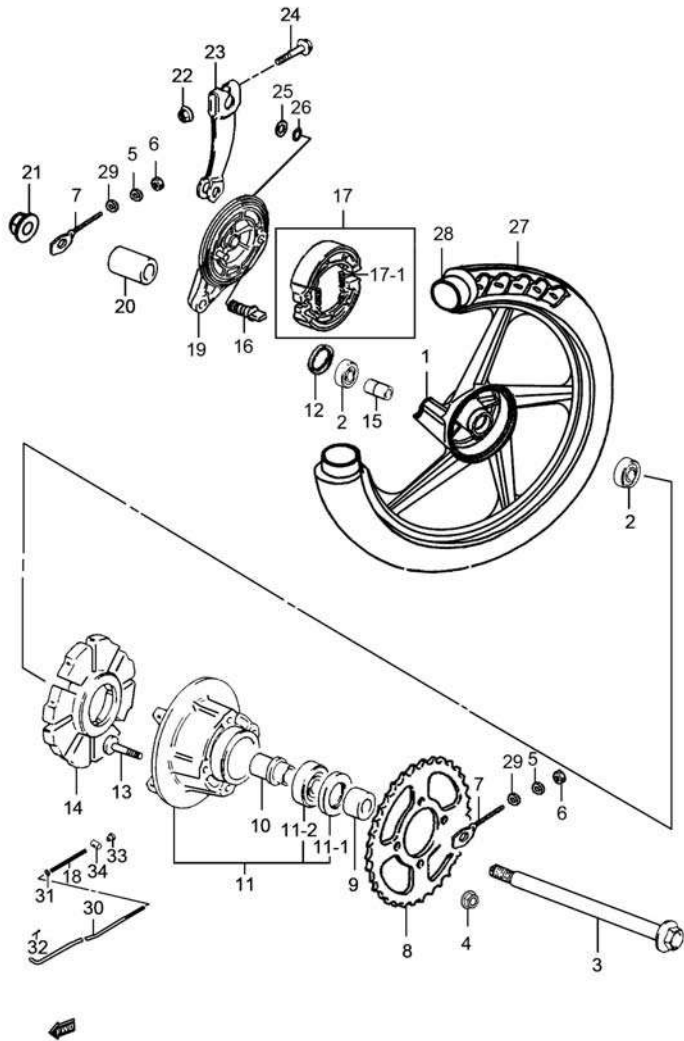
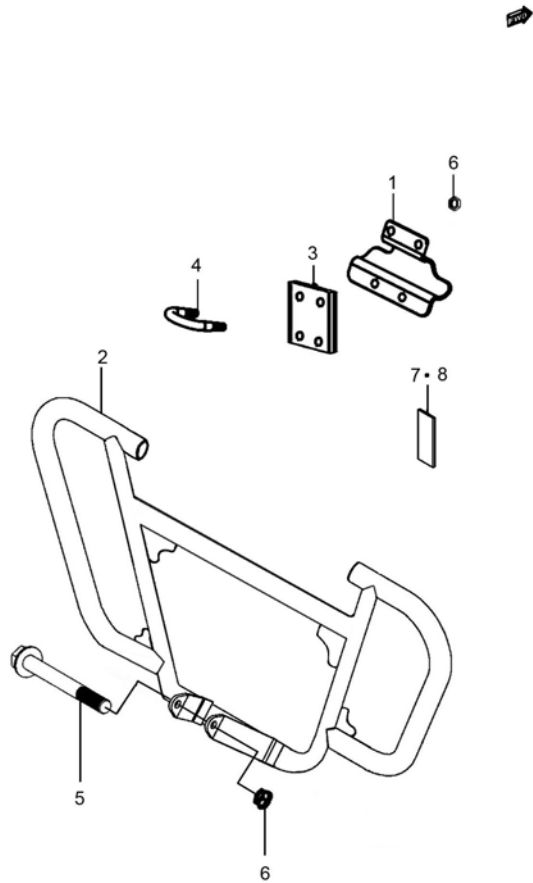

Fig.45 REAR WHEEL (P07-S460-0063)

REF. No.	PART No.	DESCRIPTION	Q' TY	REMARKS
27	65100H11040H000	TIRE COMP, REAR	1	
28	65200-45F00-000	TUBE ASSY, INNER	1	
29	08322-0108A-000	PLAIN WASHER	2	
30	43310H11700H000	ROD COMP, REAR BRAKE	1	
31	08322-0106A-000	WASHER, PLAIN	2	
32	04111-2015A-000	COTTER PIN	1	
33	09150-06001-000	NUT, REAR BRAKE ROD ADJUSTER	1	
34	43321H11200H000	PIN	1	



Fig. 46



**Fig.46 BUMPER COMP (P07-S470-0007)**

REF. No.	PART No.	DESCRIPTION	Q' TY	REMARKS
1	94221H12910H000	PLATE, FRONT BUMPER UPPER FIT	1	
2	94210H12910H000	BUMPER COMP, FRONT	1	
3	94214H12900H000	BRACKET, BUMPER	1	
4	94222H12900H000	U BOLT	2	
5	09103-08016-000	BOLT, ENG MTG (L80)	1	
6	08319-3108A-000	NUT	5	
7	94219H12910H000	CUSHION, FRONT BUMPER	1	
8	94219H12920H000	CUSHION, FRONT BUMPER	1	

4

Fig. 47

**Fig.47 CARRIER (P07-S480-0011)**

REF. No.	PART No.	DESCRIPTION	Q' TY	REMARKS
1	46310H11A30H000	CARRIER COMP, REAR	1	
2	01550-0850A-000	HEXAGON BOLT WITH FLANGE	2	

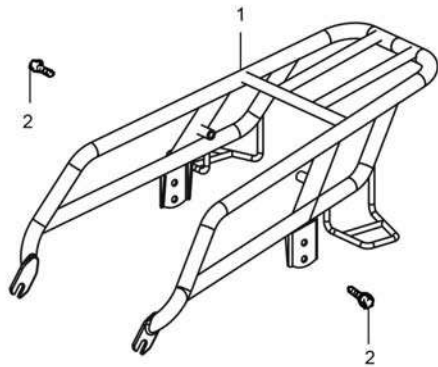

4



PART NO.	FIG. NO. – REF. NO.	PART NO.	FIG. NO. – REF. NO.	PART NO.	FIG. NO. – REF. NO.	PART NO.	FIG. NO. – REF. NO.
<b>00000</b>		01550-0616A-000	12-9	03541-0408B-000	40-10	08319-3108A-000	27-5
		01550-0616B-000	33-8	03541-0412B-000	40-11	08319-3108A-000	29-8
		01550-0616B-000	40-9	03541-0512B-000	26-9	08319-3108A-000	45-4
		01550-0620A-000	12-7	04111-2015A-000	45-32	08319-3108A-000	46-6
		01550-0620A-000	36-6	04111-2020A-000	43-12	08319-3110A-000	03-15
01500-0525A-000	19-3	01550-0620B-000	36-3	04111-2525A-000	28-4	08319-3110A-000	27-11
01500-0610A-000	07-16	01550-0625A-000	20-6	04221-04109-000	16-7	08319-3112A-000	42-1
01500-0620A-000	16-21	01550-0625A-000	25-2	06111-06004-000	41-15	08319-3112A-000	43-3
01500-0820A-000	16-14	01550-0625A-000	41-20	07130-0610A-000	15-10	08319-3114A-000	45-21
01500-0825A-000	17-6	01550-0633A-000	42-7	07130-0816B-000	39-3	08321-0106B-000	35-6-6
01547-0612A-000	12-17	01550-0633A-000	45-24	07130-0825A-000	11-1	08321-0108A-000	45-5
01547-0612A-000	03-3	01550-0812B-000	41-10	08110-60060-000	15-2	08322-0106A-000	45-31
01547-0614A-000	03-10	01550-0816B-000	34-18	08110-62040-000	15-6	08322-0108A-000	39-2
01547-0616A-000	12-15	01550-0820B-000	34-19	08123-60047-000	45-11-2	08322-0108A-000	45-29
01547-0620A-000	08-8	01550-0830B-000	41-7	08124-63027-000	45-2	08331-31129-000	16-15-6
01547-0620A-000	01-6	01550-0835B-000	41-9	08133-63017-000	42-5	08331-31149-000	16-15-2
01547-0620A-000	04-28	01550-0850A-000	47-2	08211-15251-000	15-1-3	08331-3115A-000	17-5-3
01547-0620B-000	35-5-8	01560-0608B-000	44-9	08211-15301-000	15-4-15	08331-31208-000	42-18-4
01547-0620B-000	35-6-7	01570-0840A-000	41-11	08211-20271-000	15-4-2	08331-31209-000	15-1-5
01547-0625A-000	04-22	01580-0616B-000	33-6	08310-0006A-000	09-2	08331-31209-000	15-4-8
01547-06287-000	04-29	01580-0820B-000	29-3	08310-0006A-000	22-2	08361-3506A-000	21-2
01547-0630A-000	18-2	01580-0825B-000	29-9	08310-0006A-000	35-6-5	09103-08016-000	46-5
01547-0635A-000	01-11	02112-0406A-000	30-4	08310-0008A-000	45-6	09103H08013H000	27-7
01547-0640A-000	04-23	02112-0418A-000	16-19	08313-2006B-000	10-8	09103H08015H000	03-12
01547-0645A-000	04-25	02112-0516A-000	19-2	08316-1005A-000	25-5	09103H08015H000	27-14
01547-0650A-000	03-5	02112-1520A-000	21-8	08316-1006A-000	30-9	09103H10003H000	03-13
01547-0650A-000	04-24	02112-1520B-000	27-12	08316-1006A-000	42-9	09103H10003H000	27-15
01547-0660A-000	03-6	02112-1612B-000	32-4	08316-1006A-000	45-22	09108H06017H000	01-18
01547-0660A-000	04-26	02122-0512A-000	05-8	08316-1006B-000	21-5	09111-06061-000	40-12
01547-0670A-000	04-27	02122-0616A-000	07-7	08316-1006B-000	36-8	09111-06066-000	37-8
01550-0520A-000	14-2-1	02122-0630A-000	13-2	08316-1006B-000	37-10	09111-06107-000	33-9
01550-0612A-000	10-9	02132-0516A-000	42-12	08316-1010A-000	24-5	09111-08012-000	43-8
01550-0612B-000	20-7	02132-05257-000	22-8	08319-2106B-000	35-5-6	09111-08013-000	43-9
01550-0612B-000	26-16	02142-0510B-000	37-5	08319-3108A-000	01-21	09116-06084-000	30-7
01550-0612B-000	44-10	02142-0616B-000	34-5	08319-3108A-000	03-14	09116-06167-000	33-3

5

PART NO.	FIG. NO. – REF. NO.	PART NO.	FIG. NO. – REF. NO.	PART NO.	FIG. NO. – REF. NO.	PART NO.	FIG. NO. – REF. NO.
09128-06004-000	21-3	09181H12004H000	17-1-12	09283H14001H000	16-16	09448H24001H000	07-17
09128H06001H000	16-10	09181H12180H000	07-4	09283H16001H000	17-2	09448H48003H000	17-1-2
09128H06008H000	01-8	09181H16200H000	16-15-1	09283H20059H000	15-5	09471-12077-000	22-1-10
09128H06010H000	08-9	09181H17240H000	15-4-10	09289H05001H000	07-1	09471-12081-000	23-1-3
09135H08004H000	08-4	09181H20001H000	17-1-6	09320-08051-000	10-6	09471-12128-000	25-1-2
09135H12001H000	17-3	09181H20270H000	15-1-10	09320H10022H000	30-5	09471-12177-000	24-1-2
09136-05040-000	10-1-5	09205H03001H000	04-30	09320H12007H000	34-20	09471-12177-000	24-2-2
09136H04003H000	25-3	09206H08004H000	04-3	09321H09001H000	37-1-1	09471-12177-000	24-3-2
09139-06078-000	11-5-1	09206H10007H000	02-3	09380H15001H000	17-1-11	09471-12177-000	24-4-2
09140H08001H000	43-11	09206H10007H000	03-1-1	09380H19001H000	17-1-9	09471-12196-000	22-1-9
09145H10003H000	44-5	09206H10007H000	04-10	09381H16001H000	05-4	09471H12001H000	23-1-2
09150-06001-000	45-33	09206H10008H000	01-9	09401-06101-000	12-19	09481-15001-000	26-11
09159H10097H000	28-11	09247-12104-000	04-8	09401-08414-000	31-3	09482H33000H000	01-16
09160-06094-000	11-5-2	09250H34001H000	44-8	09401-13409-000	12-2	09491H20070H000	09-1-19
09160-06129-000	22-5	09259-26023-000	04-6	09401-15101-000	10-4	09492H12100H000	09-1-21
09160-12073-000	43-4	09261H10005H000	06-5-4	09401-15101-000	12-5	09800H11201H000	27-8
09160H08003H000	01-13	09262H15010H000	15-3	09401-15404-000	12-18	09816-05700-000	27-16
09160H08011H000	08-5	09262H17001H000	14-8	09401H07201H000	12-12		
09160H08040H000	34-22	09262H28004H000	05-6	09402-46203-000	10-2		
09160H10001H000	44-2	09263H15002H000	15-7	09404-06429-000	26-10		
09160H12006H000	44-4	09263H23000H000	16-11	09407-12402-000	26-3		
09160H12009H000	44-3	09280-14003-000	42-16	09407-14403-000	26-4		
09160H13009H000	43-14	09280-14003-000	45-26	09407H15401H000	20-8		
09162-08008-000	43-10	09280-22008-000	04-7	09420H04002H000	05-5-1	<b>10000</b>	
09168-06122-000	11-5-3	09280H11001H000	17-4	09440-05003-000	17-5-2		
09168-12002-000	04-9	09280H18002H000	04-15	09440H04010H000	16-9	11100H36Y40H000	01-1
09169-06065-000	33-2	09280H19001H000	16-20	09440H04013H000	06-5-6	11121H36000H000	01-3
09180H06025H000	36-10	09280H33000H000	18-1-4	09440H07002H000	03-9	11123H35000H000	01-5
09180H06207H000	10-7	09280H34002H000	01-19	09440H09007H000	45-18	11141H36000H000	01-10
09180H08023H000	34-21	09280H35000H000	13-3	09440H15002H000	16-15-5	11142H35000H000	08-10
09180H12007H000	43-13	09280H35001H000	01-15	09443H05002H000	28-13	11165H35010H000	01-12
09180H12013H000	44-11	09280H35001H000	03-18	09443H14004H000	28-14	11167H12000H000	01-7
09180H15014H000	45-20	09280H63001H000	04-13	09443H18101H000	28-5	11172H35000H000	01-1-1
09181-19261-000	07-10	09280H75001H000	01-4	09448H15001H000	04-20	11174H35000H000	01-2
09181H06001H000	04-17	09283H07001H000	04-18	09448H18001H000	16-13	11210H36010H0B0	02-1

PART NO.	FIG. NO. – REF. NO.	PART NO.	FIG. NO. – REF. NO.	PART NO.	FIG. NO. – REF. NO.	PART NO.	FIG. NO. – REF. NO.
11241H36000H000	02-2	12811H35001H000	08-3	13573H12100H000	09-1-8	18610H12E00H000	12-8
11243H35000H000	02-5	12830H35060H000	08-6	13700H11A10H000	10-1	18700H12E00H000	12-3
11244H35000H000	02-4	12837H35000H000	08-7	13720H11700H000	10-1-1	18711H12E20H000	12-1
11300H36Y12H000	03-1	12840H3C000H000	07-3	13722H12600H000	10-1-3	18712H12E11H000	12-4
11340H36030H000	04-1	12842H3D000H000	07-3-1	13741H12610H000	10-1-6		
11351H36031H000	04-4	12852H33000H000	07-3-2	13780H12910H000	10-1-2	<b>20000</b>	
11361H36030H000	04-11	12861H35000H000	07-5	13781H12910H000	10-1-2-1		
11421H33040H000	03-20	12862H35000H000	07-6	13851H12600H000	10-3		
11431H36000H000	03-7	12911H36030H000	07-8	13881H12600H000	10-1-4		
11441H36031H000	04-12	12912H36000H000	07-9	13891H12600H000	10-1-7		
11481H36000H000	03-4	12921H35000H000	07-12	14181H11200H000	11-2	21111H35000H000	05-11
11482H35000H000	04-2	12922H35000H000	07-11	14181H16000H000	11-4	21210H36000H000	14-1
11483H36000H000	04-5	12931H35000H000	07-13	14182H12900H000	11-3	21346H33000H000	14-4
11971H12020H000	04-14	12932H33000H000	07-14	14305H11C60H000	11-5	21346H3E000H000	05-9
12111H36020H0B0	05-7	13111H33030H000	01-17	14791H12900H000	11-5-4	21410H36040H000	14-2
12140H36060H000	05-12	13200H12A30H000	09-1	16400H35020H000	13-1	21411H36000H000	14-2-9
12151H36000H000	05-13	13213H05200H000	09-1-12	16514H35000H000	05-1	21413H36000H000	14-2-3
12200H36060H000	05-5	13222H05200H000	09-1-3	16520H21D00H000	03-16	21441H33010H000	14-2-5
12543H36000H000	03-8	13223H05200H000	09-1-13	16520H33000H000	05-2	21441H33020H000	14-2-6
12620H36000H000	06-7	13225H05200H000	09-1-11	16521H33000H000	05-2-2	21451H33000H000	14-2-7
12623H3F000H000	06-1	13226H05200H000	09-1-17	16531H33000H000	05-2-4	21451H36000H000	14-2-8
12630H33001H000	06-5	13231H05200H000	09-1-16	16532H33000H000	05-2-1	21462H36000H000	14-2-4
12631H33000H000	06-5-2	13232H05200H000	09-1-2	16541H33000H000	03-17	21471H36000H000	14-2-2
12632H33001H000	06-5-3	13234H05200H000	09-1-15	16542H36000H000	01-14	21481H33000H000	14-3
12633H33000H000	06-5-5	13241H11300H000	09-1-4	16542H36000H000	03-19	23121H3D000H000	14-7
12642H33000H000	06-5-1	13255H05200H000	09-1-7	16551H33000H000	05-2-3	23131H3D000H000	14-6
12651H36000H000	06-3	13261H05200H000	09-1-5	16561H33000H000	05-3	23270H3D020H000	04-19
12681H36000H000	06-6	13262H05200H000	09-1-9	16581H33000H000	14-5	23285H35000H000	04-21
12683H36000H000	06-2	13263H05200H000	09-1-20	16581H33000H000	05-10	24102H3F000H000	15-1
12691H36000H000	06-4	13264H05200H000	09-1-14	18410H12E10H000	12-13	24103H36031H000	15-4
12710H35011H000	07-2	13266H05200H000	09-1-22	18441H50100H000	12-14	24121H3F000H000	15-1-1
12720H35001H000	07-2-1	13270H12000H000	09-1-1	18442-26H01-000	12-16	24131H36031H000	15-4-1
12741H35000H000	07-15	13295H21D20H000	09-1-10	18450H12E60H000	12-6	24210H3F000H000	15-1-9
12760H35020H000	08-1	13383H12000H000	09-1-18	18461H12E00H000	12-10	24221H35000H000	15-1-2
12771H35000H000	08-2	13551H12100H000	09-1-6	18463H2E002H000	12-11	24231H35000H000	15-1-8

5

PART NO.	FIG. NO. – REF. NO.	PART NO.	FIG. NO. – REF. NO.	PART NO.	FIG. NO. – REF. NO.	PART NO.	FIG. NO. – REF. NO.	
24232H33000H000	15-1-6	26300H12E10H000	17-5	33541-38210-000	21-7-3	35630H11A00H000	24-3-1	
24232H33000H000	15-4-7	26352-01000-000	17-5-1	33542-38800-000	21-7-1	35710H11A00H000	25-1	
24241H35000H000	15-1-7	26431H35010H000	04-16	33611H12911H000	20-1	35718H11A00H000	25-1-3	
24251H36000H000	15-1-4	27511H36010H000	15-8	33651H11A00H000	20-2	35720H11A00H000	25-1-1	
24311H36000H000	15-4-11	27521H33010H000	15-9	33652H11701H000	20-9	35764H11A00H000	25-1-4	
24314H35000H000	15-4-12	27600H2A000H108	15-11	33680H12920H000	20-10	35765H12900H000	40-8	
24321H35000H000	15-4-3	27620H2A000H000	15-11-1	33810H36000H000	18-1-2	35766H11A00H000	25-1-5	
24322H3E000H000	15-4-4			33860H11A00H000	20-3	35927-37G00-000	36-7	
24331H35000H000	15-4-9			34100H11A11H000	22-1	35970-04H01-000	25-4	
24341H35000H000	15-4-6			34111H11A11H000	22-1-3	36610H11A21H000	26-1	
24351H36000H000	15-4-5			34113H11A10H000	22-1-2	36619H12901H000	26-2	
24741H36000H000	03-11			34150H11A10H000	22-1-1	36651-12F10-000	36-9	
25211H35000H000	16-1	<b>30000</b>		34152H11A10H000	22-1-4	36651-45F40-000	26-8	
25231H35000H000	16-2			34156H11A10H000	22-1-6	36651H12500H000	21-10	
25241H35000H000	16-3			34173H11A10H000	22-1-7	36651H12500H000	26-6	
25311H36010H000	16-5			34174H11A10H000	22-1-8	36651H12610H000	26-5	
25314H36000H000	16-8			34810H11710H000	30-8	36651H12E01H000	37-9	
25350H35000H000	16-12	31133H2A200H000	18-1-1-1	34910H12E00H000	22-6	37011H11AB0H000	26-17	
25381H35000H000	16-6	31135H36000H000	18-1-1-2	34938H12600H000	34-12	37100H11A10H000	26-12	
25411H35000H000	16-4	31153H22500H000	18-1-3	34940H11A00H000	22-7	37101H11200H000	26-13	
25500H36020H000	16-15	31156H36000H000	18-1-7	34980H11A10H000	22-1-5	37157H12600H000	34-3	
25510H36020H000	16-15-4	31175H36000H000	18-1-1	35100H11A11H000	23-1	37200H11A00H000	35-1	
25518H35000H000	16-15-3	31264H36000H000	18-1-5	35121H11A11H000	23-1-1	37400H11A00H000	35-2	
25600H11A10H000	16-17	31281H36000H000	18-1-6	35124H11A10H000	23-1-1-1	37571H05503H000	35-2-1	
25652H16500H000	16-17-1	31800-49110-000	21-1	35151-21J00-000	37-6	37720H22500H000	16-18	
26210H3E000H000	17-1	32100H35081H000	19-1	35171H11A10H000	23-1-4	37740H12601H000	26-14	
26211H3E000H000	17-1-4	32101H35081H000	19-1-1	35174H2A110H000	23-1-5	38500H12601H000	26-15	
26221H35000H000	17-1-1	32102H35080H000	19-1-2	35601H11A01H000	24-1	38610H11222H000	24-7	
26222H35000H000	17-1-3	32111H33000H000	19-5	35602H11A01H000	24-2			
26225H35000H000	17-1-10	32113H35000H000	19-6	35603H11A01H000	24-3			
26226H36000H000	17-1-8	32115H35000H000	03-2	35604H11A01H000	24-4			
26241H35000H000	17-1-5	32491H33010H000	19-4	35610H11A00H000	24-1-1	<b>40000</b>		
26251H35000H000	17-1-7	32800H05550H000	21-4	35610H11A00H000	24-4-1			
26261H3E000H000	15-4-13	32900H12960H000	21-6	35616H11A01H000	24-6			
26263H35000H000	15-4-14	33410H05510H000	21-7	35630H11A00H000	24-2-1			
		33510-04H10-000	21-7-2					

PART NO.	FIG. NO. – REF. NO.	PART NO.	FIG. NO. – REF. NO.	PART NO.	FIG. NO. – REF. NO.	PART NO.	FIG. NO. – REF. NO.
41101H11Y70H000	27-1	44420H11700H000	31-2	<b>50000</b>		54400H11Y31H000	45-17
41291H12600H000	10-5	44428H12900H000	31-4			54400H45Y20H000	42-15
41540H11A01H000	20-5	44541H11200H000	30-11			54441H12B00H000	42-17
41560H11A00H000	20-4	44542H11A00H000	30-2			54451H11200H000	42-8
41894H11700HN00	21-9	44544-45F10-000	30-6			54492H11201H000	42-6
41919-45F00-000	01-20	45100H11A01H000	39-1		51103H11A90H000	41-1	54610H12900H000
41919-45F00-000	27-4	45160H11A00H000	39-1-1	51104H11A90H000	41-2	54613H11200H000	42-18-1
41991H16100H000	27-3	45511H11A01HA28	40-1	51117-45F40-000	41-1-6	54614H11200H000	42-18-3
41992H12920H000	27-6	45511H11A01HA30	40-1	51117-45F40-000	41-2-6	54616H11200H000	42-18-2
41993H16100H000	27-2	45511H11A01HA39	40-1	51153H12710H000	41-1-1	54621H12930H000	42-18-8
42100H12600H000	28-1	45512H11A01HA28	40-3	51153H12710H000	41-2-1	54623H11200H000	42-18-6
42112H12900H000	28-6	45512H11A01HA30	40-3	51173H12710H000	41-1-2	54626H11200H000	42-18-5
42211H11200H000	28-3	45512H11A01HA39	40-3	51173H12710H000	41-2-2	54632H12930H000	42-18-7
42278H12900H000	28-2	45513H11A00H104	40-2	51189H11A00H000	41-1-5	54711H50000H000	42-19
42310H12900H000	28-8	45513H11A00H541	40-2	51189H11A00H000	41-2-5	54741H2A000H000	42-3
42321H11200H000	28-9	45513H11A00H608	40-2	51311H11A00H000	41-3	54742-45F00-000	42-4
42322H11201H000	28-10	45518H11A00H000	40-4	51353H11200H000	41-4	54750H11200H000	42-14
43110H12910H000	28-12	45519H11A00H000	40-5	51356H11200H000	41-5	54892-45F00-000	42-2
43142H11200H000	28-7	46310H11A30H000	47-1	51410H11A00H000	41-8	55100H11A00H000	42-10
43142H21302H000	28-15	47111H11A00HA28	32-1	51571H11A00H000	41-1-3	55200-45F00-000	42-11
43310H11700H000	45-30	47111H11A00HA30	32-1	51571H11A00H000	41-2-3	55421H11200H000	42-15-1
43321H11200H000	45-34	47111H11A00HA39	32-1	51575H11A00H000	41-1-4	55421H11200H000	45-17-1
43510H12E01H000	29-1	47211H11A00HA28	32-2	51575H11A00H000	41-2-4	56110H11A10H000	34-1
43551H12E00H000	29-2	47211H11A00HA30	32-2	51611H11200H000	27-1-1	56171H11A01H000	34-2
43610H11A20H000	29-4	47211H11A00HA39	32-2	51611H11200H000	41-16	56211H12600H000	41-6
43618H12900H000	29-6	47312H02100H000	32-6	51621H11200H000	41-14	56270H11A10H000	34-8
43710H11A20H000	29-5	47320H11A00H000	32-7	51622H11200H000	41-17	56314-20E00-000	40-13
43718H12900H000	29-7	47330H11700H000	32-8	51625H11200H000	41-12	56500H11260H000	34-6
44011H11AMOHF01	30-1	47432H11700H000	27-13	51626H11200H000	41-13	56600H11260H000	34-7
44011H11AMOHF02	30-1	47600H11202H000	32-5	51630H11200H000	41-18	57110-28G10-000	35-4
44011H11AMOHF03	30-1	47641H11200H000	32-3	53111H11A00H000	33-1	57211-45FB0-000	35-3
44200H11A00H000	30-3			53112H11A00H000	33-5	57300-36H10-000	35-6
44256H12600H000	26-7			53211H11A00H000	33-4	57311-36H00-000	35-6-1
44256H12600H000	30-10			54110H11A10H801	42-13	57341-36H00-000	35-8
44300H11A00H000	31-1			54200H12930H000	42-18	57421-36H00-000	35-6-2

**5**

PART NO.	FIG. NO. – REF. NO.	PART NO.	FIG. NO. – REF. NO.	PART NO.	FIG. NO. – REF. NO.
57431-36H00-000	35-6-10	63119H11200H000	36-4	<b>90000</b>	
57431-45C01-000	35-5-5	63121H11A00H000	40-6		
57441-45C00-000	35-5-3	63141H11200H000	36-2		
57441-45F00-000	35-6-3	64150H11A10H801	45-1		
57442-45C00-000	35-5-4	64210H11000H000	45-19		
57442-45F00-000	35-6-4	64311H11700H000	43-7	94041H11A30HA28	37-1
57460-45F00-000	35-6-8	64441H12B00H000	45-16	94041H11A30HA30	37-1
57500-053D0-000	35-5	64451H12B00H000	45-23	94041H11A30HA39	37-1
57511-053B0-000	35-5-2	64492H11200H000	45-25	94210H12910H000	46-2
57512-45F00-000	35-5-7	64511H11A00H000	45-8	94214H12900H000	46-3
57512-45F00-000	35-6-9	64541H12800H000	45-13	94219H12910H000	46-7
57621-053C0-000	35-5-1	64610H11A00H000	45-11	94219H12920H000	46-8
57661-05300-000	35-7	64612H11200H000	45-11-1	94221H12910H000	46-1
58100H11A11H000	34-10	64614H11A00H000	45-10	94222H12900H000	46-4
58200H11A20H000	34-13	64651H11A00H000	45-14	94260H11A00H000	34-17
58300H11A11H000	34-9	64653H11A00H000	45-12	94270H11A00H000	34-16
58410H12910H000	34-11	64711H12800H000	45-3	94280H11A00H000	34-15
58620H11A00H000	34-14	64733H11A00H000	45-9	94415H11A00H000	37-4
58620H11A10H000	34-4	64916H11A00H000	45-15	94425H11A00H000	37-3
58621H11A00H000	33-7	65100H11040H000	45-27	94434H12E00H000	37-1-2
<b>60000</b>		65200-45F00-000	45-28	94434H12E00H000	40-7
		68130H11A20HR94	32-9	94500H11A00H000	41-19
		68130H11A20HR95	32-9	94550H11A00H000	37-7
		68130H11A20HR96	32-9	94577H12E00H000	37-2
		68140H11A20HR94	32-10	99011H11A80H000	38-2
61100H12801H000	43-1	68140H11A20HR95	32-10		
61200H11200H000	43-2	68140H11A20HR96	32-10		
61211H11700H000	43-6	68170H12E00H000	22-4		
61273H11700H000	43-5	68171H22500H000	22-3		
61310H12902H000	44-6	68311H30180H000	27-9		
61320H12902H000	44-7	68319-29F00-000	38-1		
61410H12901H000	45-7	68332H11210H000	38-3		
62100H11220H000	44-1	68389-45F00-000	27-10		
63112H11700H000	36-1				
63113H11A01H000	36-5				



# HAOJUE EG150X PARTS CATALOGUE

---

1st Edition

Published in 2017.6

## DACHANGJIANG GROUP CO.,LTD.

No.5, Jiandabei Rd., Jiangmen City, Guangdong Province, P.R.China

Tel: 86-750-3288999 Fax: 86-750-3230989 Code: 529000

---

DACHANGJIANG GROUP COPYRIGHT POSSESSION.

DACHANGJIANG GROUP CO. , LTD.