

Haojue

PARTS CATALOGUE

XPRESS

PREFACE

This catalogue lists the spare parts used for the following model. Please do refer to the parts catalogue and indicate the parts number and the name listed in this catalogue correctly when you need to replace the spare parts.

Design Code	Factory Reference No. (Abbr. form in the catalogue)	Engine Reference No.	Engine Cad No.
XPRESS	FA173HD220-XXE05	EG3HD03-E05	10091H3H002H000

一、 How to place an order for spare parts?

1. Required document:

The number must be provided as follow when order the spare parts:

- (a) The Engine parts: parts number and the Engine number
- (b) The Body parts: parts number and the Frame number

2. Revision

The Revised Version would be published at a suitable time when the parts Catalogue needed to be revised or renewed. In this case, the edition number would be marked on the cover. The parts would have some difference because our products are improved continuously and the modified parts no. will not be informed before the new edition published.

二、 How to use the parts catalogue?

1. Size

The unit of the parts' size indicated in the catalogue is 'mm', for example:

Parts name	Description
Bolt 6×12	Diameter 6mm, Length 12mm

O Ring D: 3.0, ID: 29.5	Section diameter 3mm, inner diameter 29.5mm
Bearing 35×72×17	Inner diamete 35mm, Outer diameter 72mm, Thickness 17mm

2. Abbr.

The meaning of the Abbreviations in the catalogue are as the followings:

D: Section diameter NT: Number of Teeth L: Length ID: Inner diameter W: Width

OPT: Optional T: Thickness OD: Outer diameter OS: Over size

STD: Standard US: Under size LH: Left hand side RH: Right hand side

3. Assy and the inner parts

The part number with a hyphen '-' in the front means this part could be supplied with the Assy (or the comp.), also could be supplied separately.

For example:

Item 1 CYCLINDER HEAD ASSY

Item1-1 PIN,CAMSHAFT COVER

That means Item1-1 can be supplied with Item 1 and aslo can be supplied seperately.

4. The illustrations in the catalogue are just for the purpose to distinguish the parts. There might be some discrepancies between the illustrations and the real parts.. Furthermore, the illustrations can not be used for the assembling purpose. When assembling, pls use the Service Manual of the relative models.

5. The instruction for the color parts

The catalogue lists are being supervised by color code.

For example: Assy,Fuel Tank 44100H22000HF01 F01 is the colour code and means "RED" .

When place an order for the color parts, please use the correct parts number (with the color code), based on the compound color sheet of the models.

This catalogue is edited according to the datas before 2019-9-10. The modification after that time should refer to the latest SPS(Spare Parts Modification notice).

XPRESS COLOR TABLE FA173HD220–XXE05 4 COLOR STYLES

REF. NO.	DESCRIPTION	PART NO.	a01 BLACK	a02 RED	a03 BLUE	a04 PURPLE	REMARKS
1	FUEL TANK SET	44011H17400H000	F01	F02	F03	F04	
2	TAPE, FUEL TANK, R	68115H17300H000	TC7	TC8	TC9	TG7	NOT SUPPLY
3	TAPE, FUEL TANK, L	68116H17300H000	TC7	TC8	TC9	TG7	NOT SUPPLY
4	COVER SET, FRAME, R	47011H17400H000	F01	F01	F02	F01	NOT SUPPLY
5	TAPE, FRAME COVER, R	68135H17300H000	TC7	TC7	TC9	TC7	
6	COVER SET, FRAME, L	47021H17400H000	F01	F01	F02	F01	NOT SUPPLY
7	TAPE, COVER SIDE, L	68136H17300H000	TC7	TC7	TC9	TC7	

1

INFORMATION ILLUSTRATION INDEX

2

ENGINE & TRANSMISSION

3

ELECTRICAL

4

BODY

5

PARTS NUMBER INDEX

Fig. 1 CYLINDER HEAD&CYLINDER HEAD COVER (P10-S010-0001)

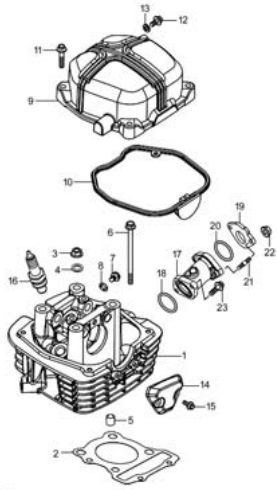

Fig. 2 CYLINDER (P10-S020-0001)

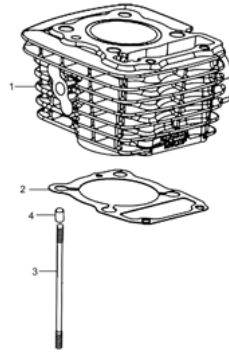

Fig. 3 CRANKCASE (P10-S030-0001)

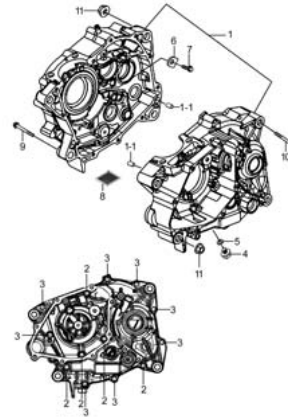

Fig. 4 CRANKCASE COVER (P10-S040-0001)

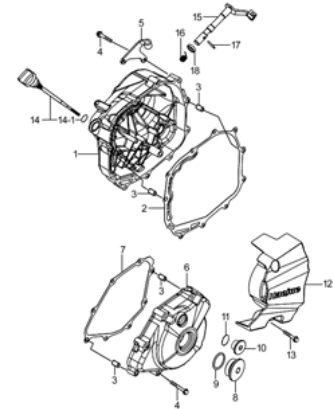

Fig. 5 CRANKSHAFT (P10-S050-0001)

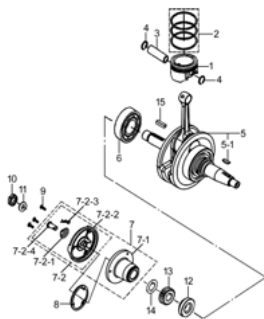

Fig. 6 STARTER CLUTCH (P10-S060-0001)

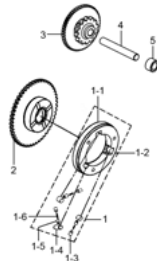

Fig. 7 CAMSHAFT-VALVE (P10-S070-0001)

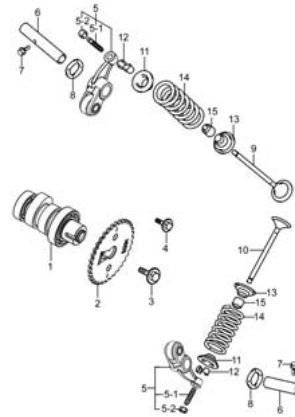
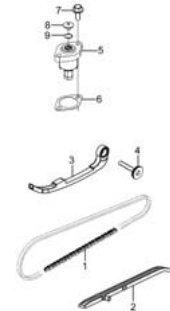

Fig. 8 CAM CHAIN (P10-S080-0001)



1

Fig. 9 CARBURETOR (P10-S090-0002)

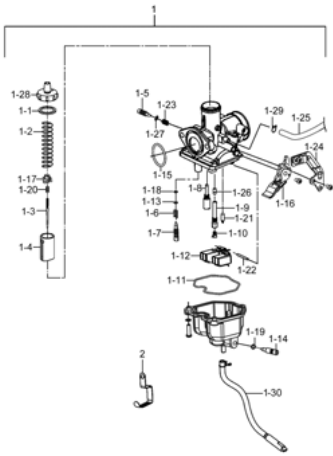

Fig. 10 AIR CLEANER (P10-S100-0001)

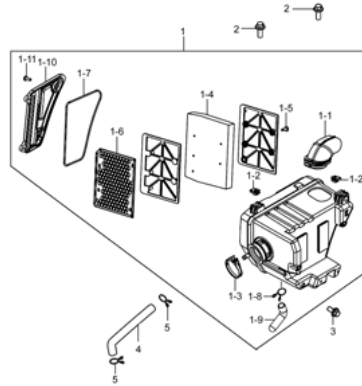

Fig. 11 MUFFLER (P10-S110-0001)

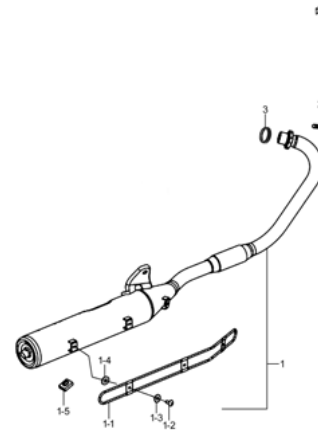

Fig. 12 OIL PUMP (P10-S130-0001)

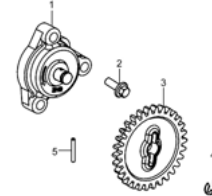

Fig. 13 CLUTCH (P10-S140-0001)

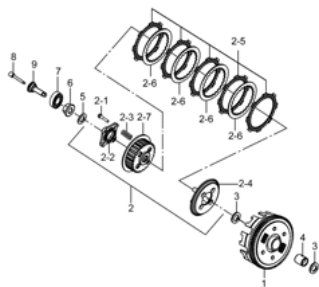

Fig. 14 TRANSMISSION (P10-S150-0001)

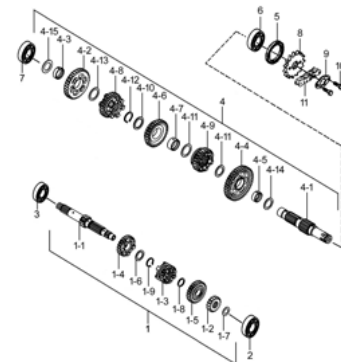

Fig. 15 GEAR SHIFTING (P10-S160-0001)

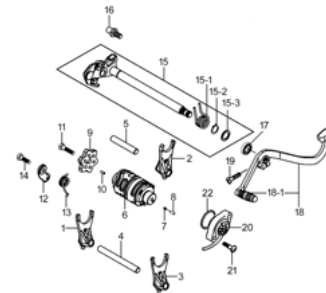
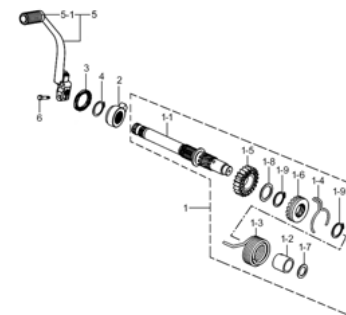

Fig. 16 KICK STARTER (P10-S165-0001)



1

Fig. 25 WIRING HARNESS (P10-S250-0001)

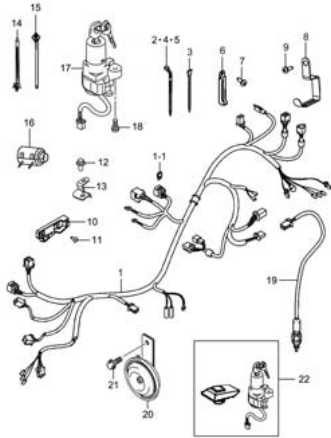

Fig. 26 FRAME (P10-S260-0001)

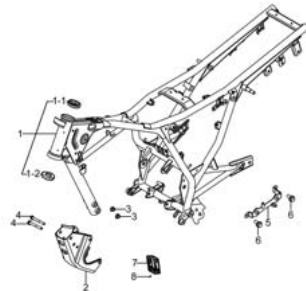

Fig. 27 STAND (P10-S270-0001)

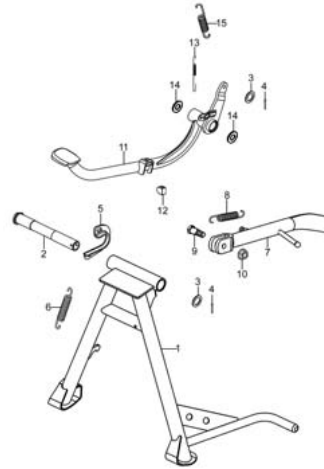

Fig. 28 FOOTREST (P10-S280-0001)

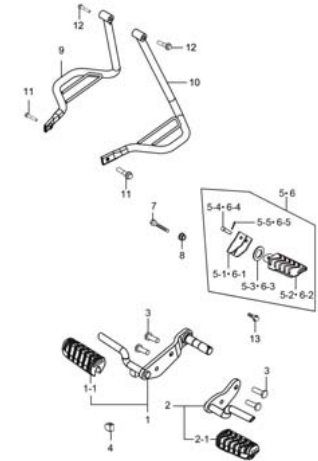

Fig. 29 FUEL TANK (P10-S290-0001)



Fig. 30 FUEL COCK (P10-S300-0001)

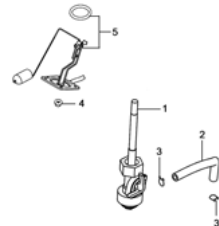

Fig. 31 FRAME COVER (P10-S310-0001)

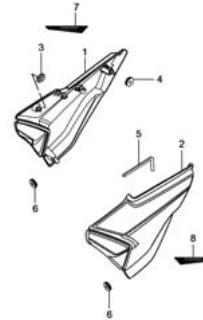
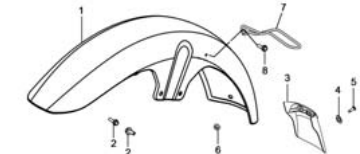

Fig. 32 FRONT FENDER (P10-S320-0001)



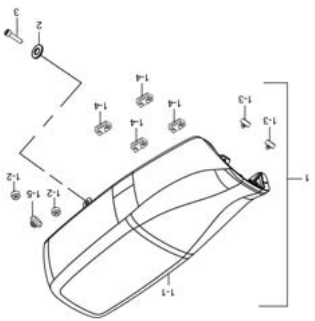

Fig. 37 SEAT (P10-S380-0001)

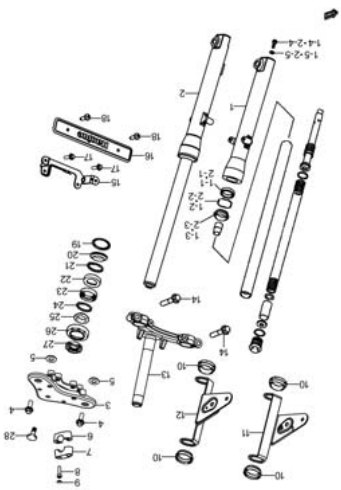

Fig. 38 STEERING STEM (P10-S400-0001)

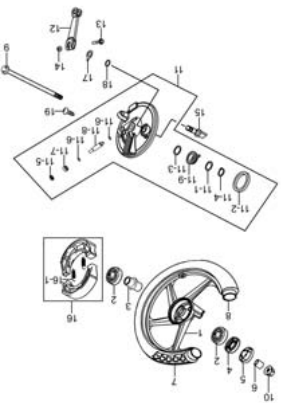

Fig. 39 FRONT WHEEL (P10-S410-0001)

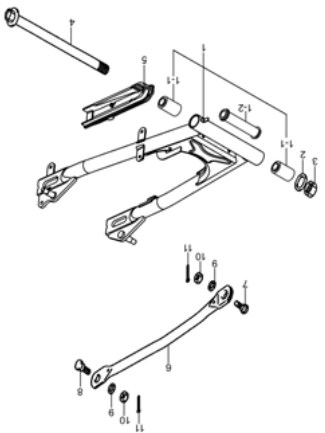

Fig. 40 REAR SWINGING ARM (P10-S440-0001)

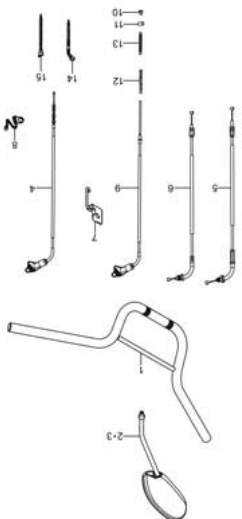

Fig. 33 HANDLEBAR (P10-S330-0001)

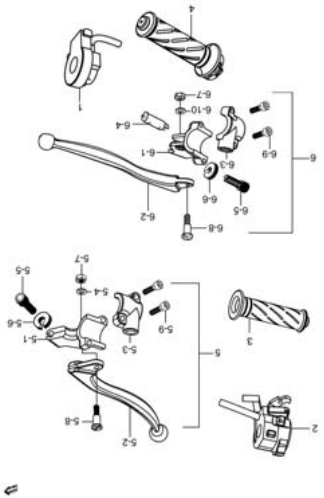

Fig. 34 HANDLE SWITCH (P10-S340-0001)

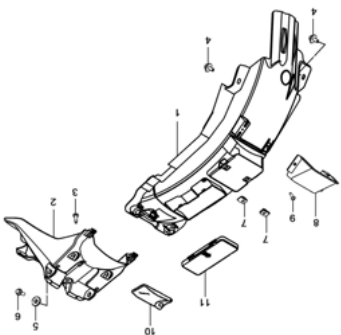

Fig. 35 REAR FENDER (P10-S350-0001)

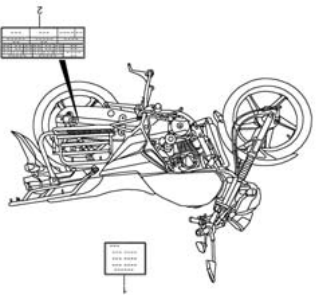

Fig. 36 LABEL (P10-S370-0001)



1

Fig. 41 REARSHOCK ABSORBER
(P10-S450-0001)

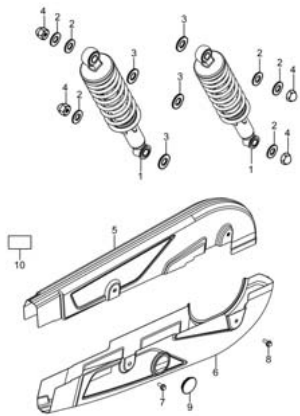

Fig. 42 REAR WHEEL (P10-S460-0001)

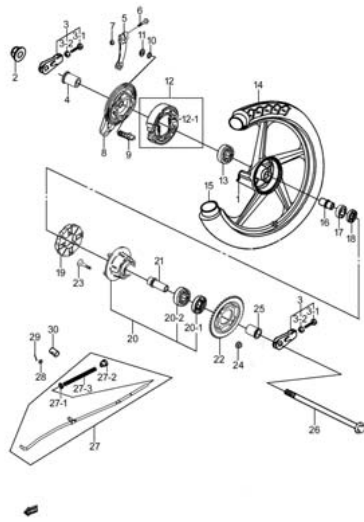

Fig. 43 CARRIER (P10-S480-0001)

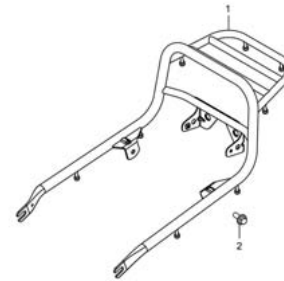

Fig. 1

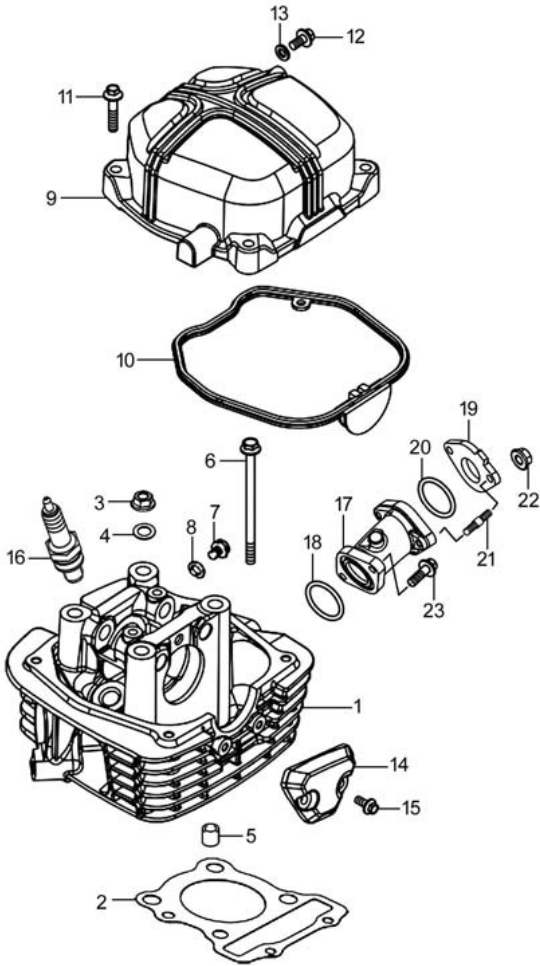

Fig.1 CYLINDER HEAD&CYLINDER HEAD COVER (P10-S010-0001)

REF. No.	PART No.	DESCRIPTION	Q'TY	REMARKS
1	11110H3H000H000	HEAD COMP, CYLINDER	1	
2	11141H3H000H000	GASKET, CYLINDER HEAD	1	
3	08316-1008A-000	HEXAGON FLANGE NUT	4	
4	09160-08039-000	WASHER, PLAIN	4	
5	04211-11169-000	PIN, CRANKSHAFT COVER, R	2	
6	09103H06003H000	BOLT	2	
7	09247-10001-000	PLUG, OIL DRAIN (M10x12)	1	
8	09168-10L01-000	GASKET	1	
9	11170H3H000H000	COVER COMP, CYLINDER HEAD	1	
10	11173H3H000H000	GASKET, CYL HEAD COVER	1	
11	01547-0630A-000	BOLT	4	
12	01547-0612A-000	HEXAGON BOLT WITH FLANGE	1	
13	09168-06018-000	GASKET	1	
14	11121H3H000H000	COVER, CYLINDER HEAD, L	1	
15	01547-0512A-000	BOLTS, HEXAGON HEAD FLANGE	2	
16	09482-00621-000	PLUG, SPARK (CPR7EA-9)	1	
17	13111H3H000H000	PIPE, INTAKE	1	
18	09280H28002H000	O-RING	1	
19	13128H3H000H000	INSULATOR, INTAKE PIPE	1	
20	09280H32001H000	O-RING	1	
21	09108H06009H000	STUD BOLT	2	
22	08310-0006A-000	NUT	2	
23	01550-0620A-000	BOLTS, HEXAGON HEAD FLANGE	2	

2

Fig.2

Fig.2 CYLINDER (P10-S020-0001)

REF. No.	PART No.	DESCRIPTION	Q' TY	REMARKS
1	11210H3H010H000	CYLINDER COMP	1	
2	11241H3H000H000	GASKET, CYLINDER	1	
3	09108H08011H000	stud bolt	4	
4	04211-11129-000	PIN, CYLINDER HEAD	2	

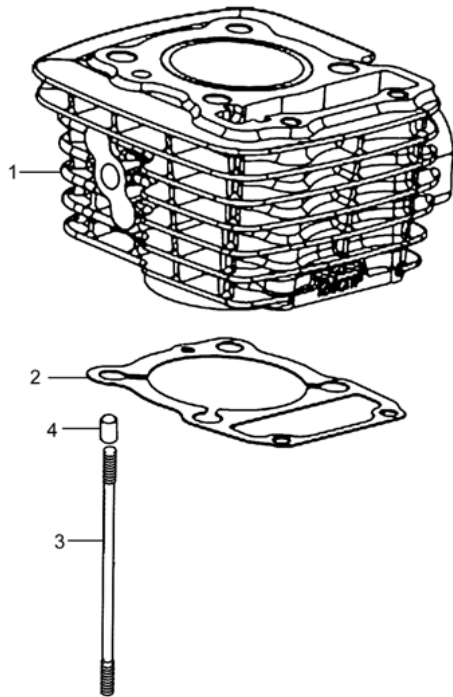

2



Fig. 3

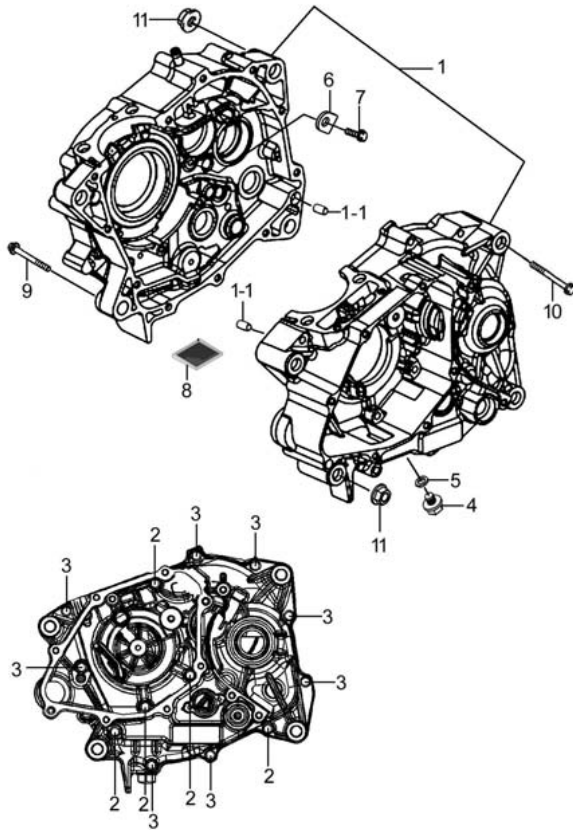

Fig.3 CRANKCASE (P10-S030-0001)

REF. No.	PART No.	DESCRIPTION	Q'TY	REMARKS
1	11300H3HY00H000	CRANKCASE SET	1	
1-1	09206H10007H000	PIN, KNOCK	2	
2	01547-0655A-000	HEXAGON BOLT WITH FLANGE	5	
3	01547-0645A-000	BOLT	8	
4	09247H12105H000	PLUG	1	
5	09168H12001H000	GASKET	1	
6	24741H3J000H000	RETAINER, CNTR SHAFT BEARING	2	
7	01547-0616A-000	BOLT	2	
8	16520-09410-000	STRAINER COMP, ENGINE OIL	1	
9	09103H10010H000	BOLT, HEXAGON	2	
10	09103H10003H000	BOLT, HEXAGON	2	
11	08319-3110A-000	NUT	4	

2

Fig. 4

Fig.4 CRANKCASE COVER (P10-S040-0001)

REF. No.	PART No.	DESCRIPTION	Q' TY	REMARKS
1	11340H3H000H000	COVER COMP, CLUTCH	1	
2	11482H3H000H000	GASKET, CLUTCH COVER	1	
3	09206H08004H000	PIN, KNOCK	4	
4	01547-0640A-000	BOLTS, HEXAGON HEAD FLANGE	19	
5	11421H3H000H000	BRACKET, CLUTCH CABLE	1	
6	11351H3H000H000	COVER, MAGNETO	1	
7	11483H3H000H000	GASKET, MAGNETO COVER	1	
8	09259H32002H000	PLUG	1	
9	09280-32006-000	O-RING, INTAKE PIPE	1	
10	11353H3J010H000	PLUG, TIMING OBSERVATION HOLE	1	
11	09280H13010H000	O-RING	1	
12	11360H17300H000	COVER COMP, ENG SPROCKET	1	
13	01547-0630A-000	BOLT	2	
14	11091H3H000H000	GAUGE SET, OIL LEVEL	1	
14-1	09280H18002H000	O RING	1	
15	23270H3H000H000	SHAFT COMP, CLUTCH RELEASE	1	
16	09448H15001H000	SPRING, TORSION	1	
17	09205H03001H000	PIN, SPRING	1	
18	23285H3H000H000	SEAL, OIL	1	

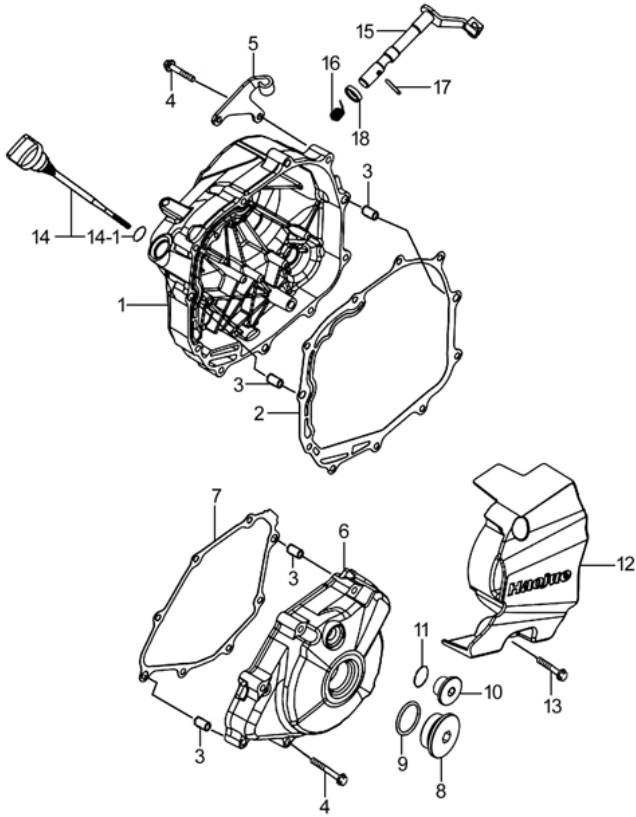

2



Fig. 5

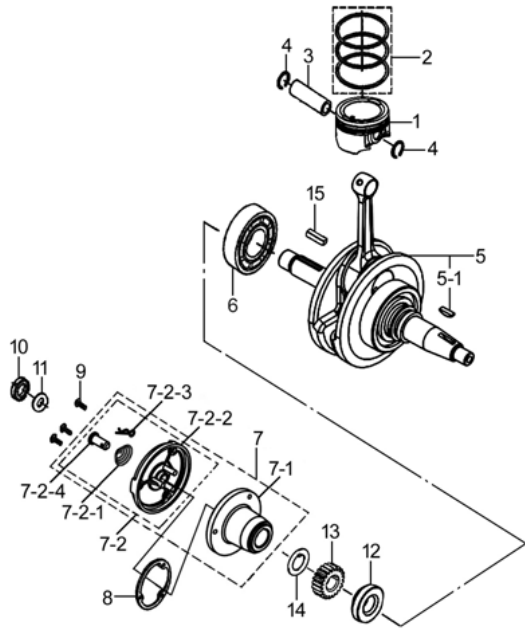

Fig.5 CRANKSHAFT (P10-S050-0001)

REF. No.	PART No.	DESCRIPTION	Q'TY	REMARKS
1	12111H3H000H000	PISTON	1	
2	12140H29000H000	RING SET, PISTON	1	
3	12151H3H000H000	PIN, PISTON	1	
4	09381-14001-000	CIRCLIP	2	
5	12200H3H000H000	CRANKSHAFT ASSY	1	
5-1	09420H04002H000	KEY	1	
6	09262H30001H000	BEARING	1	
7	16052H3D010H000	FILTER SET, ENGINE OIL	1	
7-1	16514H3D000H000	FILTER ROTOR, ENG OIL	1	
7-2	16520H33040H000	COVER ASSY, ENGINE OIL FILTER	1	
7-2-1	16532H33000H000	SPRING	1	
7-2-2	16521H33040H000	COVER, ENGINE OIL FILTER	1	
7-2-3	16551H33040H000	PIN, COTTER	1	
7-2-4	16531H33040H000	TUBE, OIL PASSING	1	
8	16561H33000H000	GASKET, ROTOR COVER	1	
9	02122-0512A-000	CROSS RECESSED HEAD SCREW	3	
10	21346H33000H000	NUT, LOCK	1	
11	09160H16004H000	WASHER, PLAIN	1	
12	21113H3H000H000	WASHER, PRIMARY DRIVE GEAR	1	
13	21111H3H010H000	GEAR, PRIMARY DRIVE	1	
14	09166H18002H000	WASHER	1	
15	09421H04003H000	KEY	1	

2



Fig. 6

Fig.6 STARTER CLUTCH (P10-S060-0001)

REF. No.	PART No.	DESCRIPTION	Q' TY	REMARKS
1	12630H33010H000	HUB COMP, STARTER CLUTCH	1	
1-1	12642H33010H000	PLATE, STARTER CLUTCH HUB	1	
1-2	12631H33010H000	HUB, STARTER CLUTCH	1	
1-3	12632H33010H000	PLUG, STARTER CLUTCH HUB	3	
1-4	09261H10008H000	ROLLER	3	
1-5	12633H33010H000	PIECE, STARTER CLUTCH RLR PUSH	3	
1-6	09440H04017H000	SPRING, COMPRESSION	3	
2	12620H3H000H000	GEAR COMP, STARTER CLUTCH	1	
3	12611H3H000H000	GEAR, STARTER IDLE	1	
4	12612H3H000H000	SHAFT, STARTER IDLE GEAR	1	
5	09180H08021H000	SPACER	1	

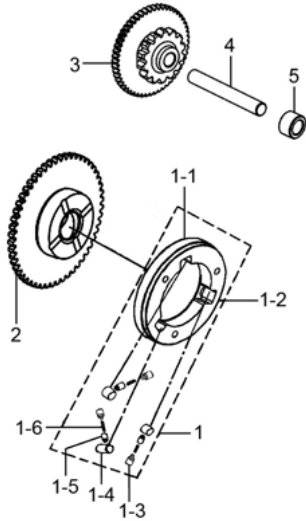

2



Fig. 7

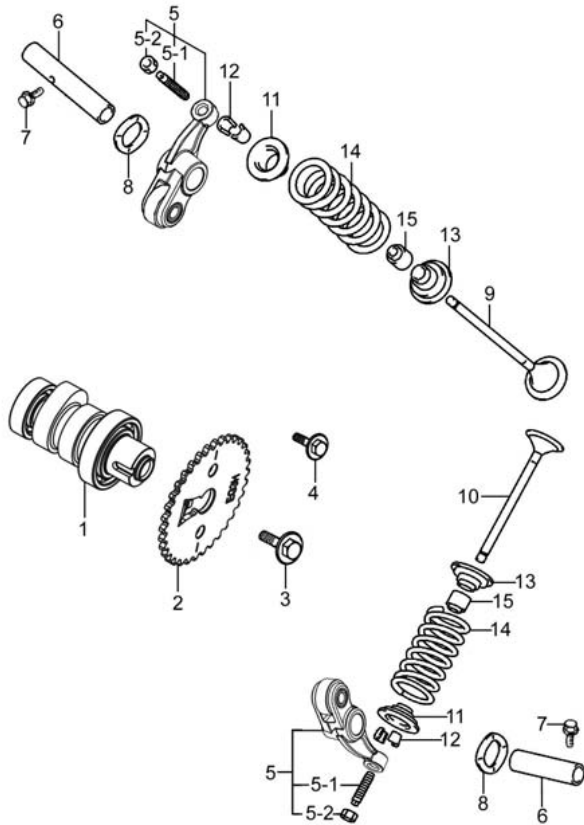

Fig.7 CAMSHAFT-VALVE (P10-S070-0001)

REF. No.	PART No.	DESCRIPTION	Q'TY	REMARKS
1	12710H3H000H000	CAMSHAFT COMP	1	
2	12741H3H000H000	SPROCKET, CAMSHAFT	1	
3	12742H16200H000	BOLT, CAMSHAFT SPROCKET	1	
4	09116H06004H000	BOLT WITH WASHER	1	
5	12840H16200H000	ARM COMP, VALVE ROCKER	2	
5-1	12842H16200H000	SCREW, TAPPET ADJUSTING	1	
5-2	12843H12000H000	NUT, TAPPET ADJUSTING	1	
6	12861H3H000H000	SHAFT, VALVE ROCKER ARM	2	
7	09103H05001H000	BOLT	2	
8	09164-10012-000	WASHER, WAVE	2	
9	12911H16200H000	VALVE, INTAKE	1	
10	12912H16200H000	VALVE, EXHAUST	1	
11	12931H50100H000	RETAINER VALVE SPRING	2	
12	12932H50100H000	COTTER VALVE	4	
13	12933H16200H000	SEAT, VALVE SPRING	2	
14	12921H3H000H000	SPRING, VALVE	2	
15	09289H05004H000	SEAL, OIL	2	

2



Fig. 8

Fig.8 CAM CHAIN (P10-S080-0001)

REF. No.	PART No.	DESCRIPTION	Q' TY	REMARKS
1	12760H20G00H000	CHAIN COMP, CAMSHAFT DRIVE	1	
2	12771H3H000H000	GUIDE, CAM CHAIN	1	
3	12811H3H000H000	TENSIONER, CAM CHAIN	1	
4	12812H3H000H000	BOLT, TENSIONER	1	
5	12830H29011H000	ADJUSTER ASSY, TENSIONER	1	
6	12837H50100H000	GASKET, TENSIONER ADJUSTER	1	
7	01547-0620A-000	BOLT	2	
8	09125H06002H000	SCREW	1	
9	09280H09011H000	O-RING	1	

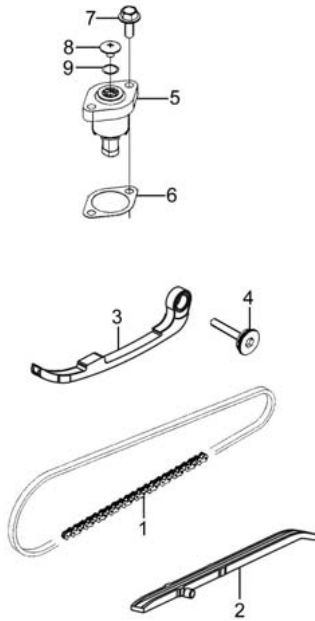

2



Fig. 9

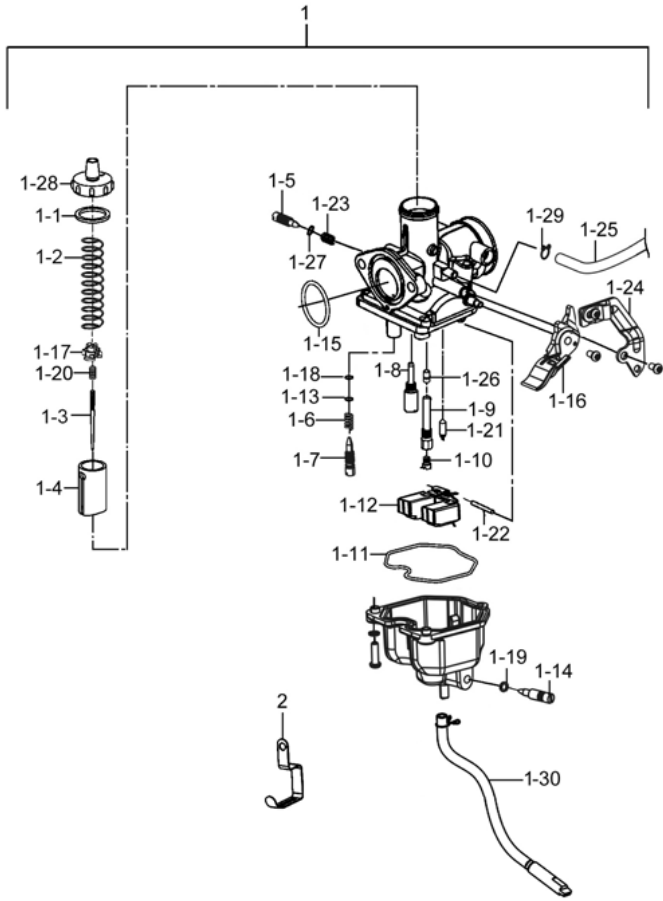

Fig.9 CARBURETOR (P10-S090-0002)

REF. No.	PART No.	DESCRIPTION	Q'TY	REMARKS
1	13200H17310H000	CARBURETOR ASSY	1	
1-1	13255H11200H000	TOP GASKET	1	
1-2	13573H17300H000	COMPRESSION SPRING	1	
1-3	13383H17300H000	JET NEEDLE	1	
1-4	13551H17300H000	VALVE, PISTON	1	
1-5	13267H12700H000	ADJUSTER	1	
1-6	13268H33000H000	SPRING COMPR	1	
1-7	13279H17300H000	ADJUSTER	1	
1-8	13351H17300H000	JET, PILOT	1	
1-9	13385H17300H000	JET HOLDER	1	
1-10	09491H11210H000	JET, MAIN	1	
1-11	13251H111A10H000	GASKET	1	
1-12	13252H33000H000	FLOAT COMP	1	
1-13	13262H11200H000	WASHER	1	
1-14	13247H33000H000	DRAIN SCREW	1	
1-15	13253H33000H000	O RING	1	
1-16	13432H33000H000	LEVER CHOKE	1	
1-17	13389H12700H000	CAP, JET NEEDLE	1	
1-18	13295H21D00H000	O RING	1	
1-19	13225H11200H000	O RING	1	
1-20	13388H12700H000	COMPRESSION SPRING	1	
1-21	13370H21D00H000	VALVE ASSY, NEEDLE	1	
1-22	13254H21D00H000	PIN	1	
1-23	13494H12700H000	COMPRESSION SPRING	1	
1-24	13270H12900H000	BRACKET	1	
1-25	13684H17300H000	AIR VENT HOSE	1	
1-26	09494H12700H000	NEEDLE JET	1	
1-27	13299H12700H000	X RING	1	
1-28	13261H12700H000	MIXING CAP	1	

2

Fig.9

Fig.9 CARBURETOR (P10-S090-0002)

REF. No.	PART No.	DESCRIPTION	Q' TY	REMARKS
1-29	13224H2A000H000	CLIP, DRAIN HOSE	1	
1-30	13683H17310H000	HOSE, DRAIN	1	
2	36651-26H60-000	CLAMP, WIRING HARNESS	1	

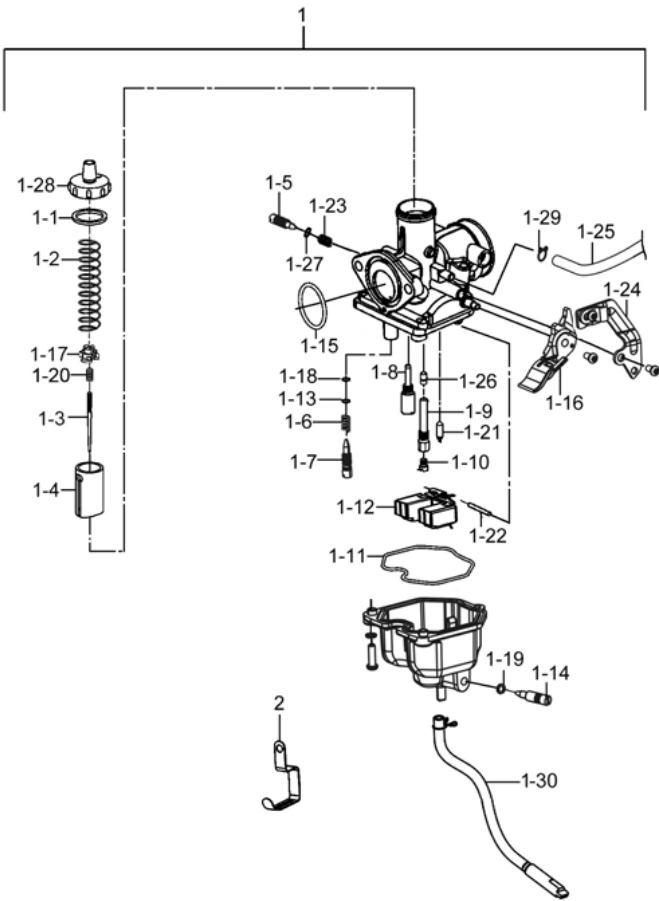

2



Fig. 10

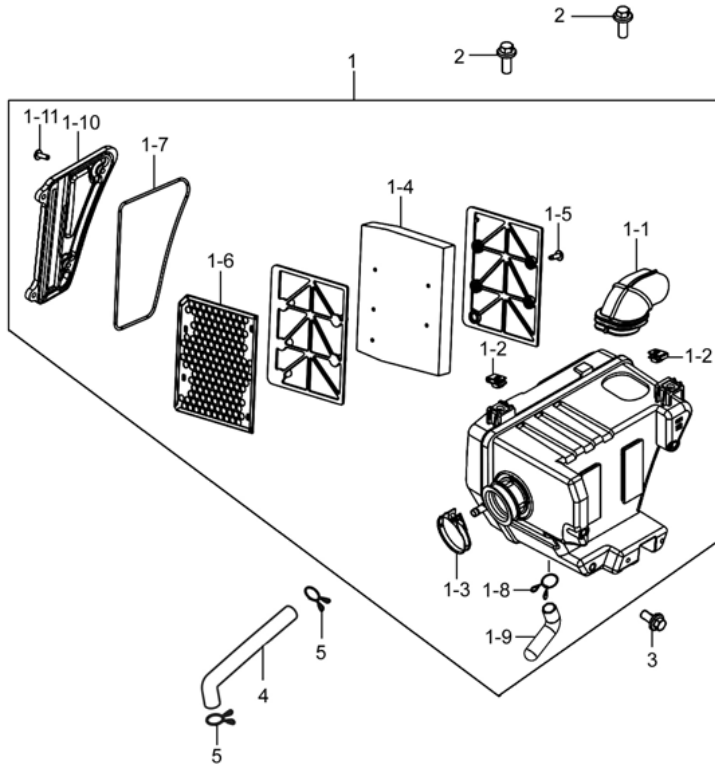

Fig.10 AIR CLEANER (P10-S100-0001)

REF. No.	PART No.	DESCRIPTION	Q'TY	REMARKS
1	13700H17400H000	CLEANER ASSY, AIR	1	
1-1	13891H17300H000	TUBE, INLET	1	
1-2	35157H37200H000	NUT	2	
1-3	13170H2C002H000	CLAMP, OUTLET TUBE	1	
1-4	13781H17300H000	FILTER, AIR CLNR	1	
1-5	03541-0516A-000	CROSS RECESSED HEAD TAPPING SCREW	4	
1-6	13810H17300H000	TRAP COMP, FLAME	1	
1-7	13723H17400H000	GASKET, AIR CLNR CAP	1	
1-8	09401H13201H000	CLIP	1	
1-9	13863H22500H000	TUBE, DRAIN	1	
1-10	13741H17400H000	CAP, AIR CLNR	1	
1-11	02142-0516A-000	CROSS RECESSED HEAD SCREW	4	
2	01550-0616A-000	BOLT	2	
3	01550-0612A-000	BOLT	1	
4	13851H17300H000	TUBE, BREATHER	1	
5	09401-11102-000	CLIP	2	

2

Fig. 11

2

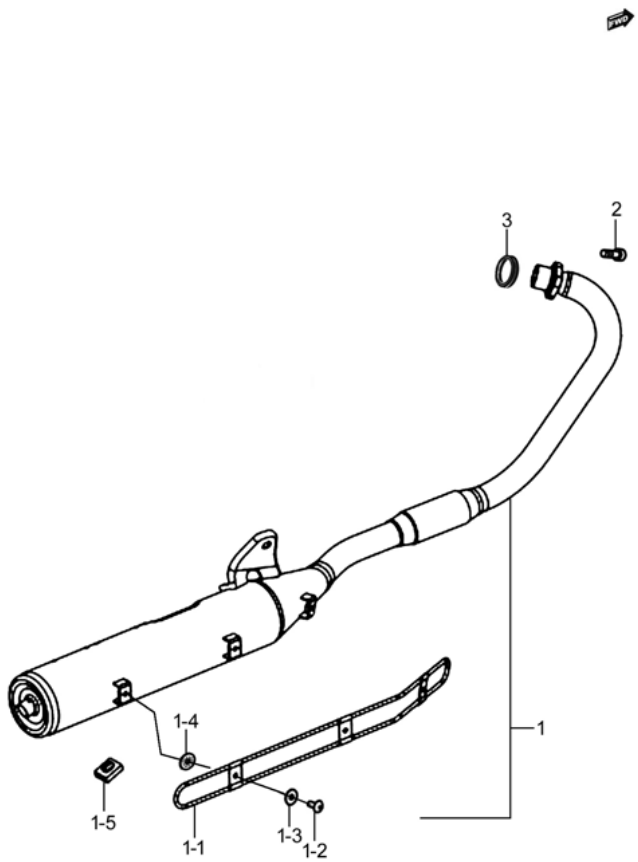

Fig.11 MUFFLER (P10-S110-0001)

REF. No.	PART No.	DESCRIPTION	Q' TY	REMARKS
1	14036H17400H000	MUFFLER SET	1	
1-1	14780H17400H000	COVER COMP, MUF	1	
1-2	09139H06016H000	SCREW	3	
1-3	09160-06159-000	WASHER, PLAIN	3	
1-4	09168H06002H000	GASKET	3	
1-5	42278-26H00-000	STOPPER, CENTER STAND	1	
2	07130-0825A-000	BOLT	2	
3	14181-09D20-000	GASKET, EXH PIPE	1	

Fig. 12

Fig.12 OIL PUMP (P10-S130-0001)

REF. No.	PART No.	DESCRIPTION	Q'TY	REMARKS
1	16400H3H000H000	PUMP ASSY, ENG OIL	1	
2	01547-0625A-000	BOLT	3	
3	16330H3H000H000	GEAR COMP, OIL PUMP DRIVEN	1	
4	09383-06001-000	E-RING	1	
5	09261-02001-000	PIN, OIL PUMP DRIVEN GEAR	1	

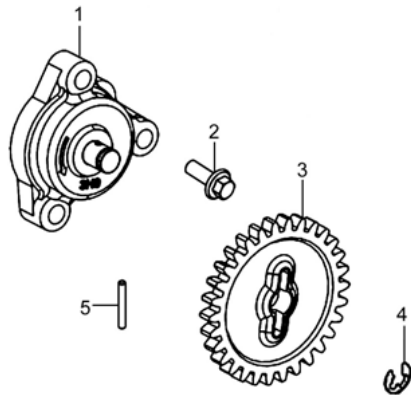

2



Fig. 13

2

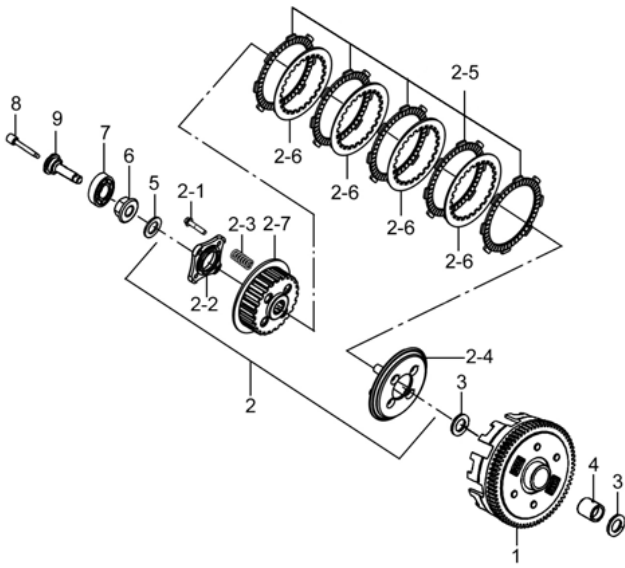

Fig.13 CLUTCH (P10-S140-0001)

REF. No.	PART No.	DESCRIPTION	Q' TY	REMARKS
1	21200H3H000H000	GEAR ASSY, PRIMARY DRIVEN	1	
2	21410H3H010H000	HUB ASSY, CLUTCH SLEEVE	1	
2-1	01550-0625A-000	BOLT	4	
2-2	21471H3G000H000	PLATE, CLUTCH PUSH ROD	1	
2-3	21413H3H000H000	SPRING, CLUTCH	4	
2-4	21462H3R000H000	DISC, CLUTCH PRESSURE	1	
2-5	21420H33000H000	PLATE GROUP, CLUTCH DRIVE	1	
2-6	21451H3E020H000	PLATE, CLUTCH DRIVEN	4	
2-7	21411H3R000H000	HUB, CLUTCH SLEEVE	1	
3	21481H3J000H000	WASHER, CLUTCH SLEEVE HUB	2	
4	21251H3H000H000	SPACER, PRIMARY DRIVEN GEAR	1	
5	21324H3J000H000	WASHER	1	
6	21346H3J000H000	NUT, LOCK	1	
7	09262H17001H000	BEARING, CLUTCH	1	
8	23131H33030H000	POLE, CLUTCH PUSH	1	
9	23121H3H000H000	PIECE, CLUTCH PUSH	1	

Fig. 14

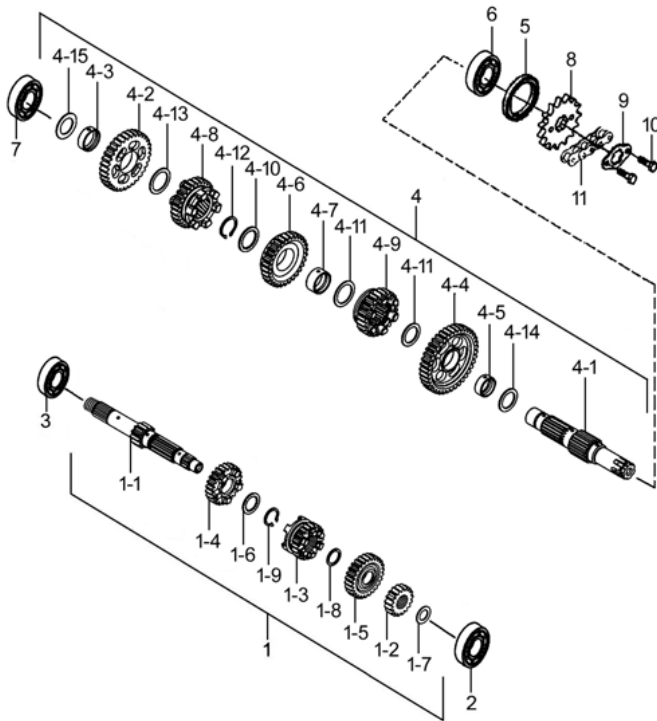

Fig.14 TRANSMISSION (P10-S150-0001)

REF. No.	PART No.	DESCRIPTION	Q'TY	REMARKS
1	24102H3H000H000	SHAFT ASSY, COUNTER	1	
1-1	24121H3H000H000	SHAFT, COUNTER	1	
1-2	24221H3H000H000	GEAR, 2ND DRIVE	1	
1-3	24231H3H000H000	GEAR, 3RD DRIVE	1	
1-4	24241H3H000H000	GEAR, 4TH DRIVE	1	
1-5	24251H3H000H000	GEAR, 5TH DRIVE	1	
1-6	24232H3H000H000	WASHER, SPL INE	1	
1-7	09160H12014H000	WASHER, PLAIN	1	
1-8	09160H15002H000	WASHER, PLAIN	1	
1-9	09380H18004H000	CIRCLIP	1	
2	09262H12018H000	BEARING	1	
3	08110-62030-000	BEARING, AXLE SHAFT, L	1	
4	24103H3H000H000	SHAFT ASSY, DRIVE	1	
4-1	24131H3H000H000	SHAFT, DRIVE	1	
4-2	24311H3H010H000	GEAR, 1ST DRIVEN	1	
4-3	24312H3J000H000	BUSH, 1ST DRIVEN GEAR	1	
4-4	24321H3H000H000	GEAR, 2ND DRIVEN	1	
4-5	24322H3J000H000	BUSH, 2ND DRIVEN GEAR	1	
4-6	24331H3H000H000	GEAR, 3RD DRIVEN	1	
4-7	24332H3J000H000	BUSH, 3RD DRIVEN GEAR	1	
4-8	24341H3H000H000	GEAR, 4TH DRIVEN	1	
4-9	24351H3H000H000	GEAR, 5TH DRIVEN	1	
4-10	24232H3J000H000	WASHER, SPL INE	1	
4-11	09160H20001H000	WASHER, PLAIN	2	
4-12	09380H18002H000	CIRCLIP	1	
4-13	09160H17002H000	WASHER, PLAIN	1	
4-14	09160H17004H000	WASHER, PLAIN	1	
4-15	09160H17006H000	WASHER, LOCK	1	
5	09283-17025-000	SEAL, OIL	1	

2

Fig. 14

Fig.14 TRANSMISSION (P10-S150-0001)

REF. No.	PART No.	DESCRIPTION	Q' TY	REMARKS
6	08110-62030-000	BEARING, AXLE SHAFT, L	1	
7	09262H17007H000	BEARING	1	
8	27511-36H00-000	SPROCKET, ENGINE (14T)	1	
9	27512-09G00-000	PLATE, ENGINE SPROCKET	1	
10	07130-0610A-000	HEXAGON SOCKET HEAD CAP SCREW	2	
11	27600H2A010H106	CHAIN ASSY, DRIVE	1	

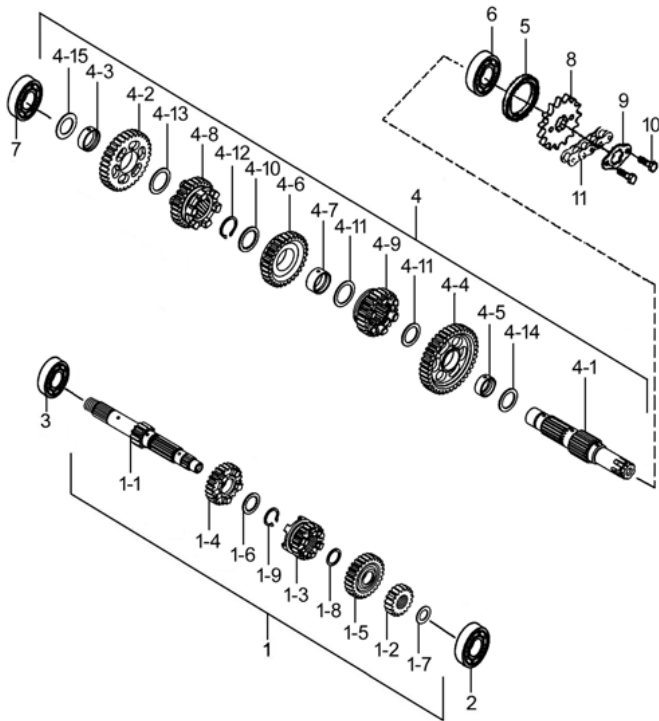

2

Fig. 16

2

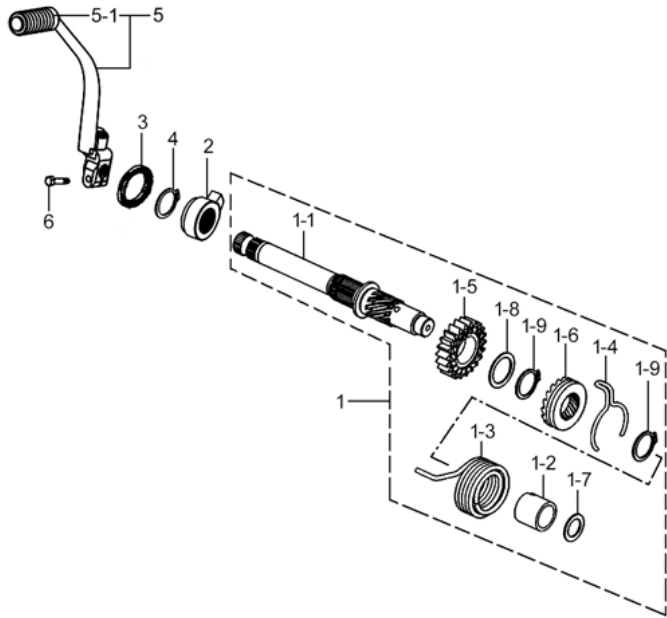

Fig.16 KICK STARTER (P10-S165-0001)

REF. No.	PART No.	DESCRIPTION	Q' TY	REMARKS
1	26210H3H000H000	SHAFT COMP, KICK STARTER	1	
1-1	26211H3H000H000	SHAFT, KICK STARTER	1	
1-2	26221H16200H000	GUIDE, KICK STARTER SHAFT SPRIN	1	
1-3	26226H3H000H000	SPRING, RELEASE	1	
1-4	26235H16200H000	SPRING, KICK STARTER IDLE FRICTION	1	
1-5	26241H3H000H000	GEAR, KICK STARTER DRIVE	1	
1-6	26282H16200H000	RATCHET, KICK STARTER DRIVEN GR	1	
1-7	09181H14003H000	SHIM	1	
1-8	09181H20002H000	SHIM	1	
1-9	08331-31209-000	CIRCLIP	2	
2	26225H3H000H000	SEAT, RELEASE SPRING	1	
3	09283H16001H000	SEAL, OIL	1	
4	08331-31189-000	CIRCLIP	1	
5	26300H3H010H000	LEVER ASSY, KICK STARTER	1	
5-1	26352H3H000H000	RUBBER, KICK STARTER LEVER	1	
6	01500-0825A-000	BOLTS, HEXAGON HEAD	1	

Fig. 17

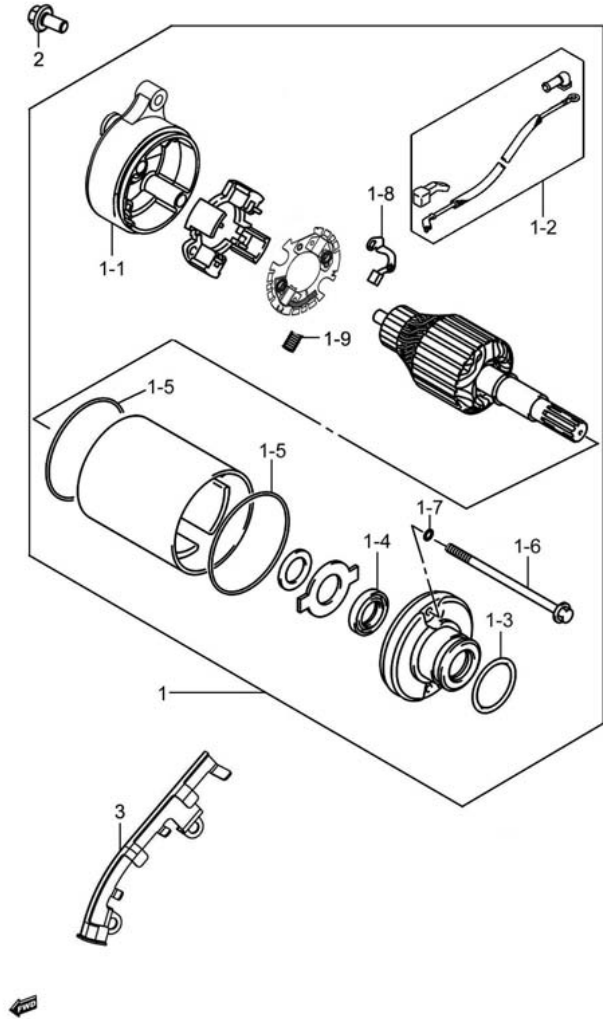

Fig.17 STARTING MOTOR (P10-S170-0001)

REF. No.	PART No.	DESCRIPTION	Q'TY	REMARKS
1	31100H3H000H000	MOTOR ASSY, STARTING	1	
1-1	31175H3H000H000	FRAME ASSY	1	
1-2	33810H3H000H000	WIRE, STARTER MOTOR	1	
1-3	31156H3H000H000	O-RING	1	
1-4	31153H3H000H000	OIL SEAL, STARTER MOTOR	1	
1-5	31156H3H020H000	O-RING	2	
1-6	31281H3H000H000	BOLT	2	
1-7	31156H3H010H000	O-RING	2	
1-8	31133H3H000H000	BRUSH, STARTER MOTOR, MINUS	1	
1-9	31135H3H000H000	SPRING, STARTER MOTOR BRUSH	2	
2	01547-0630A-000	BOLT	2	
3	36651H3H000H000	CLAMP	1	

3

Fig. 18

Fig.18 MAGNETO (P10-S180-0001)

REF. No.	PART No.	DESCRIPTION	Q' TY	REMARKS
1	32100H3H000H000	MAGNETO ASSY	1	
1-1	32101H3H000H000	STATOR ASSY	1	
1-2	32102H3H000H000	ROTOR ASSY	1	
2	01547-0616A-000	BOLT	2	
3	01547-0625A-000	BOLT	3	
4	08316-1012A-000	NUT	1	
5	32491H33010H000	BOLT, MAGNETO ROTOR	3	

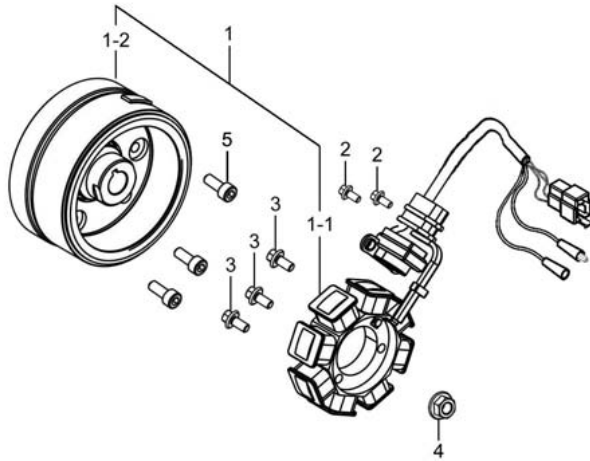

3

Fig. 19

Fig.19 BATTERY (P10-S190-0001)

REF. No.	PART No.	DESCRIPTION	Q'TY	REMARKS
1	33610H17400H000	BATTERY ASSY	1	
2	33860H17300H000	WIRE, BATTERY MINUS LEAD	1	

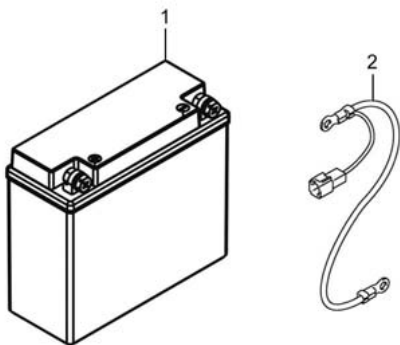

3



Fig. 20

Fig.20 ELECTRICAL (P10-S200-0001)

REF. No.	PART No.	DESCRIPTION	Q' TY	REMARKS
1	31800-49110-000	RELAY ASSY, STARTING MOTOR	1	
2	08361-3506A-000	NUT	2	
3	09128-06004-000	SCREW, STG MOT RLY	2	
4	32800H05523H000	RECTIFIER ASSY	1	
5	01550-0612A-000	BOLT	2	
6	32900H17310H000	CDI UNIT	1	
7	01550-0616A-000	BOLT	2	
8	33410H17300H000	COIL ASSY, IGNITION	1	
8-1	33510-04H10-000	CAP, SPARK PLUG	1	
8-2	33541H05500H000	SEAL, SPARK PLUG	1	
8-3	33542H05500H000	SEAL, HIGH TENSION CORD	1	
9	02112-1520A-000	CROSS RECESSED HEAD SCREW	1	

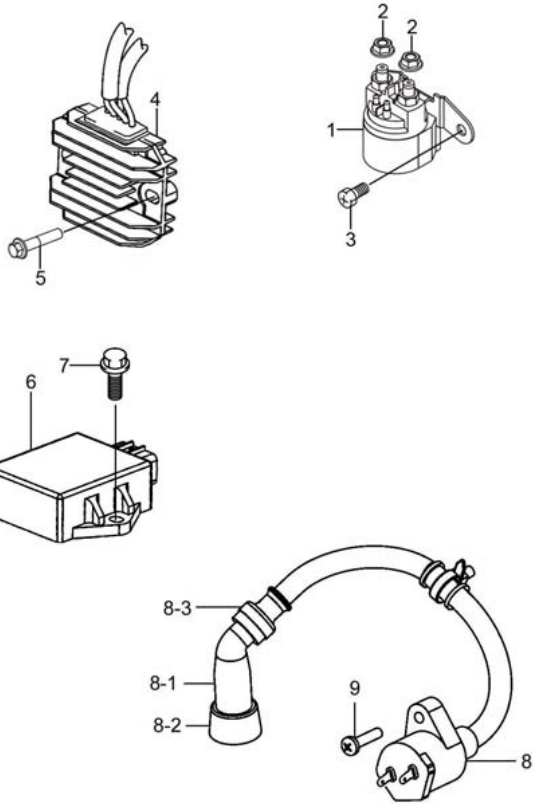

3



Fig. 21

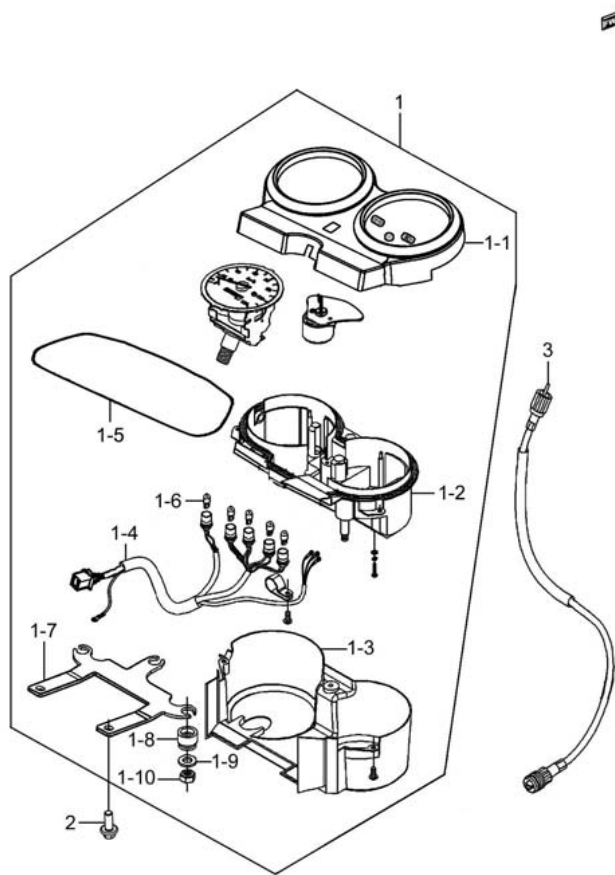

Fig.21 SPEEDOMETER (P10-S210-0001)

REF. No.	PART No.	DESCRIPTION	Q'TY	REMARKS
1	34100H17400H000	SPEEDOMETER ASSY	1	
1-1	34150H17400H000	HOOD, SPEEDOMETER	1	
1-2	34111H17400H000	CASE, SPEEDOMETER, LOWER	1	
1-3	34152H2A430H000	LOW CASE, SPEEDOMETER	1	
1-4	34173H17400H000	WIRE HARNESS, SPEEDOMETER	1	
1-5	34193H12E00H000	MOLD	1	
1-6	09471-12077-000	BULB	5	T10 12V 2W
1-7	34950H2A430H000	BRACKET, SPEEDOMETER	1	
1-8	34955-45F20-000	CUSHION, METER	3	
1-9	08322-01063-000	WASHER, LICENSE PLATE BRKT	3	
1-10	08310-11063-000	NUT	3	
2	01550-0812A-000	HEXAGON BOLT WITH FLANGE	2	
3	34910H12E01H000	CABLE ASSY, SPEEDOMETER	1	

3

Fig. 22

Fig.22 HEADLAMP (P10-S220-0001)

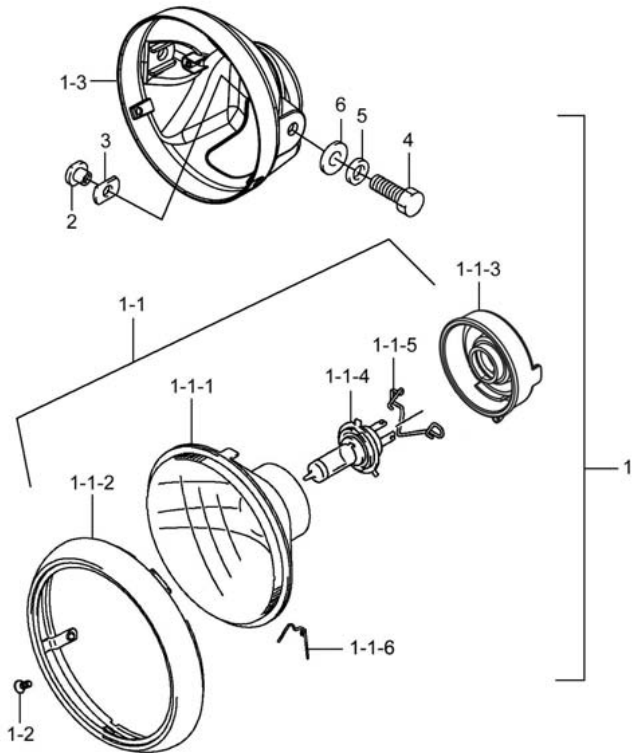

REF. No.	PART No.	DESCRIPTION	Q' TY	REMARKS
1	35011H17400H000	HEADLAMP SET	1	
1-1	35100H17400H000	HEADLAMP ASSY	1	
1-1-1	35121H17400H000	UNIT, HEADLAMP	1	
1-1-2	35111H2A410H000	RIM, HEADLAMP	1	
1-1-3	35174H2A410H000	BOOT, HEADLAMP HOUSING	1	
1-1-4	09471H12001H000	BULB (12V, 35/35W)	1	HS1 12V 35/35W
1-1-5	35172H2A410H000	SPRING, HEADLAMP SOCKET	1	
1-1-6	35128H2A410H000	SUPPORTER SPRING, HEADLAMP	4	
1-2	35181-45F10-000	SCREW, HEADLAMP	2	
1-3	51811-45F20-000	HOUSING, HEADLAMP	1	
2	51825-45F10-000	NUT, HEADLAMP HOUSING	2	
3	51827-45F10-000	CUSHION, HEADLAMP HOUSING	2	
4	01204-08207-000	BOLT	2	
5	08321-01087-000	WASHER	2	
6	08322-01087-000	PLATE WASHER	2	

3

Fig. 23

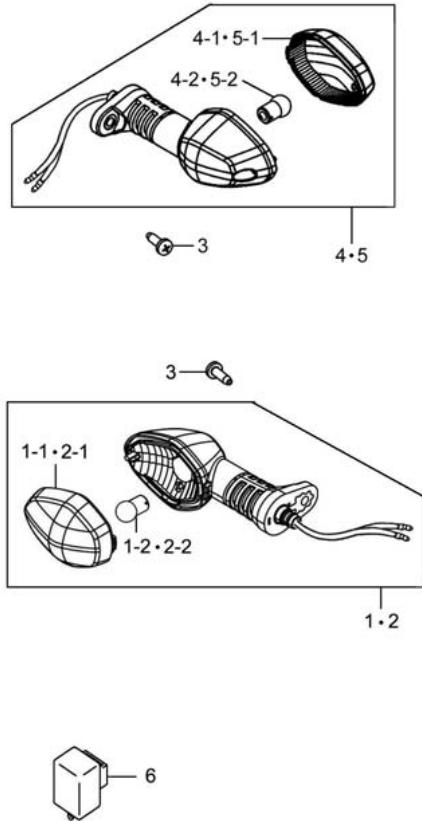

Fig.23 TURN SIGNAL LAMP (P10-S230-0001)

REF. No.	PART No.	DESCRIPTION	Q'TY	REMARKS
1	35601H17400H000	LAMP ASSY, FRONT TURNSIGNAL, R	1	
1-1	35672H56000H000	LENS, REAR TURNSIGNAL LAMP, L	1	
1-2	09471-12177-000	BULB (12V 10W)	1	12V R10W
2	35602H17400H000	LAMP ASSY, FRONT TURNSIGNAL, L	1	
2-1	35652H56000H000	LENS, REAR TURNSIGNAL, R	1	
2-2	09471-12177-000	BULB (12V 10W)	1	12V R10W
3	02142-0516B-000	CROSS RECESSED HEAD SCREW	4	
4	35603H56001H000	LAMP ASSY, REAR TURNSIGNAL, R	1	
4-1	35652H56000H000	LENS, REAR TURNSIGNAL, R	1	
4-2	09471-12177-000	BULB (12V 10W)	1	12V R10W
5	35604H56001H000	LAMP ASSY, REAR TURNSIGNAL, L	1	
5-1	35672H56000H000	LENS, REAR TURNSIGNAL LAMP, L	1	
5-2	09471-12177-000	BULB (12V 10W)	1	12V R10W
6	38610H11222H000	RELAY ASSY, TURNSIGNAL	1	

3



Fig. 24

Fig.24 REAR COMBINATION LAMP (P10-S240-0001)

REF. No.	PART No.	DESCRIPTION	Q' TY	REMARKS
1	35710H17400H000	LAMP ASSY, REAR COMB	1	
1-1	35712H17400H000	LENS, REAR COMB	1	
1-2	09471-12128-000	BULB (12V, 21/5W)	1	12V P21/5W
1-3	35713H17400H000	GASKET, REAR COMB	1	
2	08316-1006A-000	NUT	2	
3	09320-08047-000	CUSHION, SEAT TAIL COVER FRONT	2	
4	09160-06088-000	WASHER, REAR COMB LAMP	2	
5	09180-06263-000	SPACER, CYL COWLING (L9)	2	
6	08316-1005A-000	HEXAGON FLANGE NUT	1	
7	35970H2F000H000	REFLEX REFLECTOR ASSY, REAR	1	

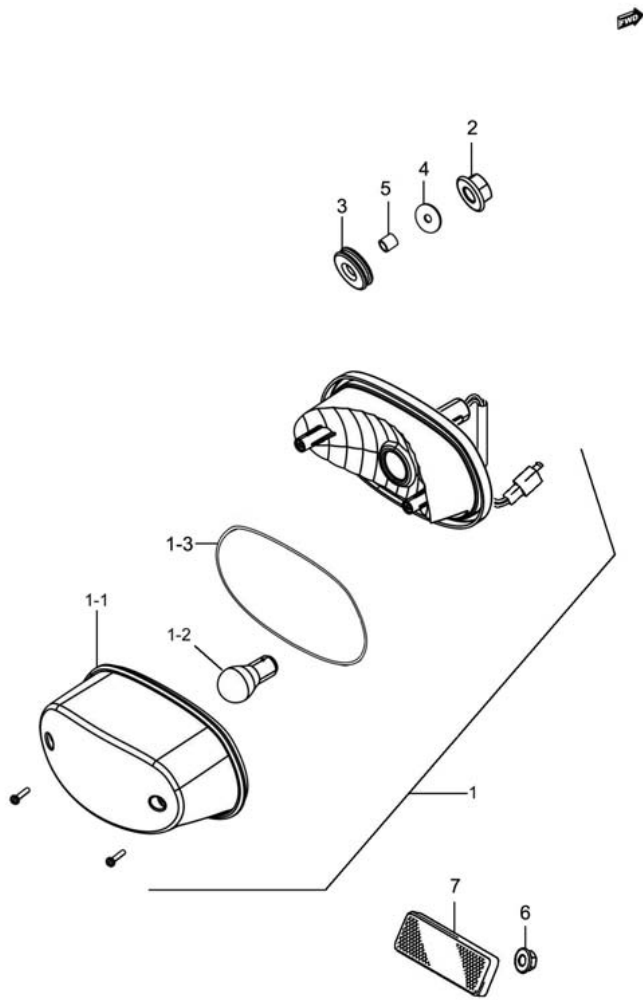

3

Fig. 25

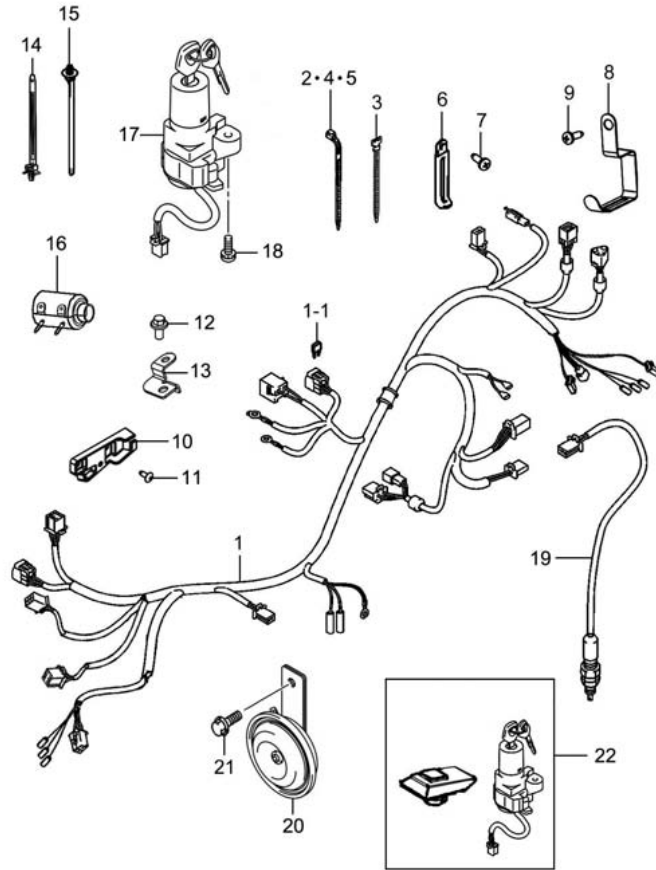

Fig.25 WIRING HARNESS (P10-S250-0001)

REF. No.	PART No.	DESCRIPTION	Q'TY	REMARKS
1	36610H17400H000	HARNESS WIRING	1	
1-1	36720H2C100H000	FUSE ASSY	2	15A
2	09407-14403-000	CLAMP, FUEL HOSE	7	L=125
3	09407-12402-000	CLAMP, WIRING HARNESS	2	L=128
4	09407-18402-000	CLAMP, FUEL FILTER NO. 2	1	L=165
5	09407-11401-000	CLAMP, WIRING HARNESS	1	L=95
6	09404-06433-000	CLAMP	2	L=95
7	03541-0412B-000	SCREW	2	
8	36651-26H60-000	CLAMP, WIRING HARNESS	1	T=55.8
9	03541-0416A-000	CROSS RECESSED HEAD TAPPING SCREW	1	
10	36619H17100H000	BRACKET, WIRING HARENESS CLAMP	1	
11	03541-0616B-000	CROSS RECESSED HEAD TAPPING SCREW	2	
12	01550-0612A-000	BOLT	1	
13	36651H17300H000	BRACKET, WIRING HARNESS CLAMP	1	
14	36651-12F10-000	CLAMP	1	
15	36990-39J00-000	CLAMP, SEAT LOCK CABLE	1	
16	36618H2A000H000	BOOT, WIRING HARNESS	1	D=60
17	37100H2E010H000	LOCK ASSY, STEERING	1	
18	09139-06048-000	BOLT, STEERING LOCK	2	
19	37740H2J000H000	SWITCH ASSY, STOP LAMP	1	
20	38500H2C000H000	HORN ASSY	1	
21	01550-0612A-000	BOLT	1	
22	37011H2E01AH000	LOCK SET	1	

3

Fig. 26

Fig.26 FRAME (P10-S260-0001)

REF. No.	PART No.	DESCRIPTION	Q' TY	REMARKS
1	41100H17Y20H000	FRAME SET	1	
1-1	51611H2A201H000	RACE, STEERING INNER UPPER	1	
1-2	51612H2A200H000	RACE, STEERING INNER LOWER	1	
2	41992H17300H000	BRACKET, ENG MTG LOWER	1	
3	08319-3110A-000	NUT	2	
4	09103H10013H000	BOLT	2	
5	41560H17400H000	BRACKET ASSY, BATTERY	1	
6	01550-0610A-000	BOLTS, HEXAGON HEAD FLANGE	2	
7	68311H56110H000	PLATE, LICENSE	1	
8	09229H03001H000	RIVET, BLIND	2	

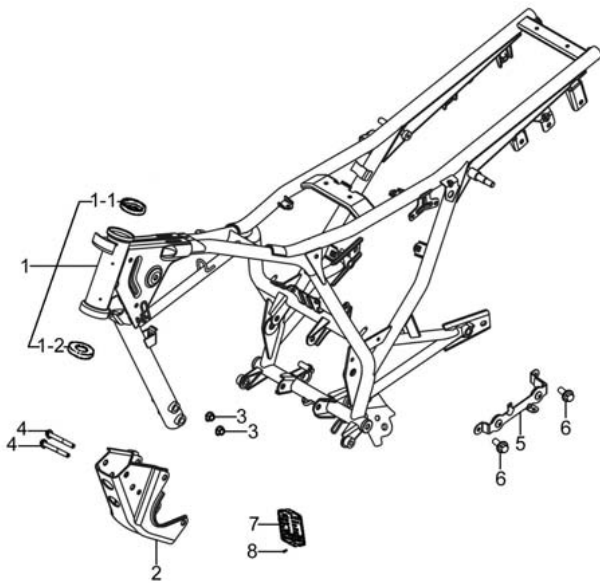

4

Fig. 27

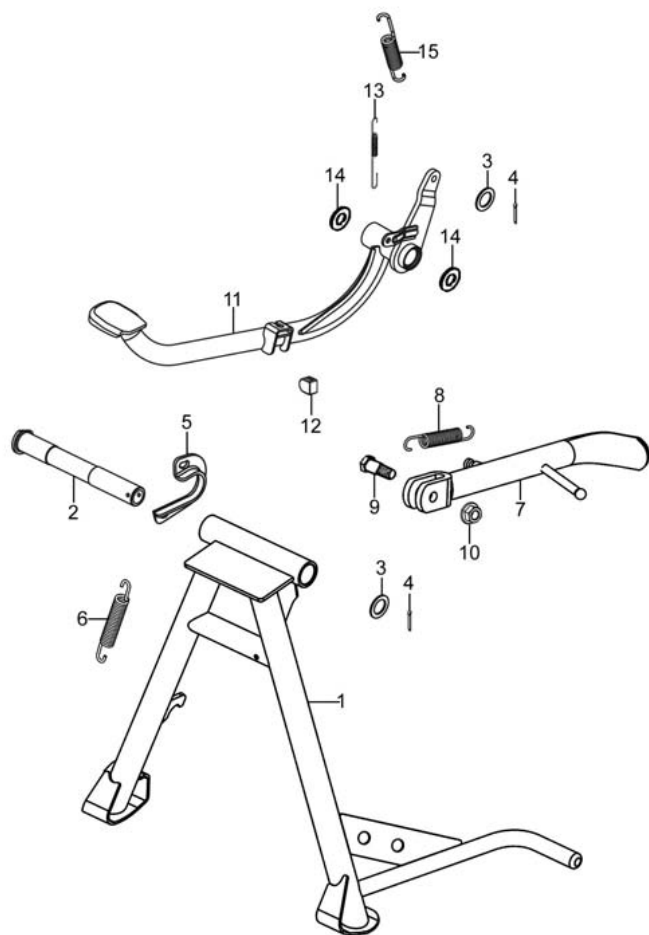

Fig.27 STAND (P10-S270-0001)

REF. No.	PART No.	DESCRIPTION	Q'TY	REMARKS
1	42100H17400H000	STAND COMP, CENTER	1	
2	42211H17100H000	SHAFT, CENTER STAND	1	
3	09160H17001H000	WASHER, PLAIN	2	
4	04111-2525A-000	COTTER PIN	2	
5	42112H2D001H000	SPRING PLATE, CENTER STAND	1	
6	09443-19020-000	SPRING, TENSION	1	
7	42310H17400H000	STAND COMP, PROP	1	
8	42241-26H10-000	SPRING, CENTER STAND	1	
9	09111H10060H000	BOLT	1	
10	08319-3110A-000	NUT	1	
11	43110H17400H000	PEDAL COMP, BRAKE	1	
12	43125H2A203H000	CUSHION, BRAKE PEDAL	1	
13	43115H36600H000	SPRING, STOP LAMP	1	
14	43116H22500H000	SEAL, BRAKE PEDAL	2	
15	09443H14004H000	SPRING, TENSION	1	

4

Fig. 28

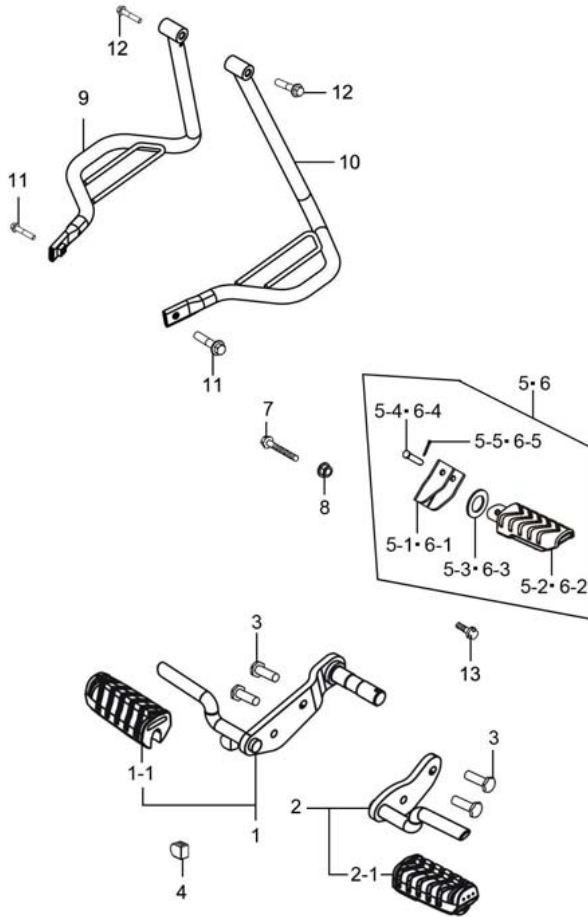

Fig.28 FOOTREST (P10-S280-0001)

REF. No.	PART No.	DESCRIPTION	Q' TY	REMARKS
1	43501H17401H000	FOOTREST ASSY, FRONT, R	1	
1-1	43551H17100H000	RUBBER, FRONT FOOTREST	1	
2	43502H17100H000	FOOTREST ASSY, FRONT, L	1	
2-1	43551H17100H000	RUBBER, FRONT FOOTREST	1	
3	01550-1025B-000	HEXAGON BOLT WITH FLANGE	4	
4	43125H2A203H000	CUSHION, BRAKE PEDAL	1	
5	43600H2A210H000	FOOTREST ASSY, PILLION, R	1	
5-1	43621H2A200H000	HOLDER, PILLION FOOTREST	1	
5-2	43612H2A200H000	RUBBER, PILLION FOOTREST	1	
5-3	43631H52100H000	WASHER, FOOTREST RUBBER	1	
5-4	09200H06004H000	PIN WITH HOLE	1	
5-5	04111-2015A-000	COTTER PIN	1	
6	43700H2A210H000	FOOTREST ASSY, PILLION, L	1	
6-1	43621H2A200H000	HOLDER, PILLION FOOTREST	1	
6-2	43612H2A200H000	RUBBER, PILLION FOOTREST	1	
6-3	43631H52100H000	WASHER, FOOTREST RUBBER	1	
6-4	09200H06004H000	PIN WITH HOLE	1	
6-5	04111-2015A-000	COTTER PIN	1	
7	01550-1050A-000	BOLT, HEXAGON HEAD FLANGE	1	
8	08319-3110A-000	NUT	1	
9	43610H17400H000	BOARD COMP, PILLION FOOTREST, R	1	
10	43710H17400H000	BOARD COMP, PILLION FOOTREST, L	1	
11	01550-0820A-000	BOLTS, HEXAGON HEAD FLANGE	2	
12	01550-0845A-000	BOLT	2	
13	01550-1020A-000	BOLT, HEXAGON HEAD FLANGE	1	

4

Fig. 29

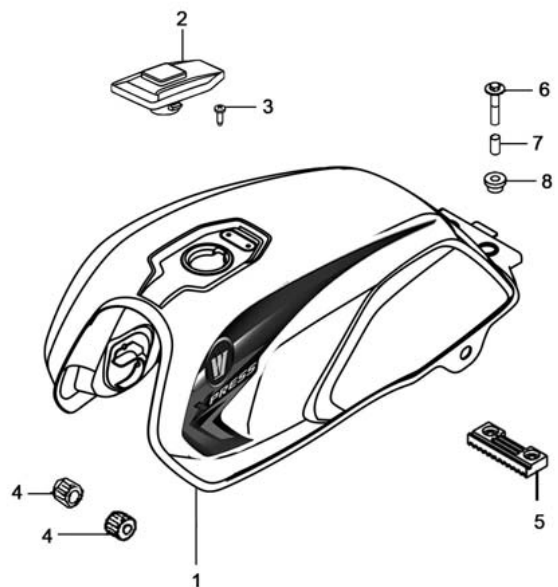

Fig.29 FUEL TANK (P10-S290-0001)

REF. No.	PART No.	DESCRIPTION	Q'TY	REMARKS
1	44011H17400HF01	FUEL TANK SET (BLACK)	1	
1	44011H17400HF02	FUEL TANK SET (RED)	1	
1	44011H17400HF03	FUEL TANK SET (BLUE)	1	
1	44011H17400HF04	FUEL TANK SET (PURPLE)	1	
2	44200H11750H000	CAP ASSY, FUEL TANK FILLER	1	
3	02112-0406A-000	CROSS RECESSED HEAD SCREW	2	
4	44541H11200H000	CUSHION, FRONT	2	
5	44542-38300-000	CUSHION, FUEL TANK REAR NO. 1	1	
6	09116-06084-000	BOLT, FUEL TANK REAR	2	
7	09180-06067-000	SPACER, FUEL TANK REAR	2	
8	09320H10022H000	CUSHION	2	

4



Fig. 30

Fig.30 FUEL COCK (P10-S300-0001)

REF. No.	PART No.	DESCRIPTION	Q' TY	REMARKS
1	44300H2A240H000	COCK ASSY, FUEL	1	
2	44421H17300H000	HOSE, OUTLET	1	
3	09401H08302H000	CLAMP	1	
4	08316-1006A-000	NUT	4	
5	34810H17400H000	GAUGE ASSY, FUEL LEVEL SENDER	1	

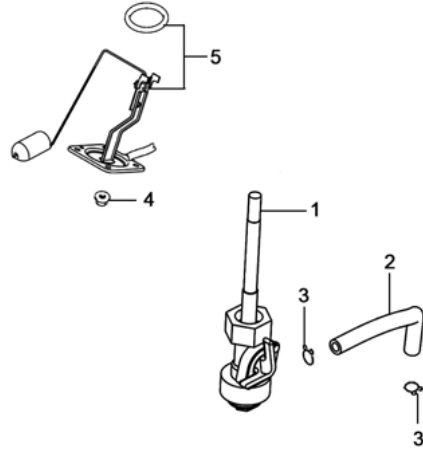

4



Fig. 31

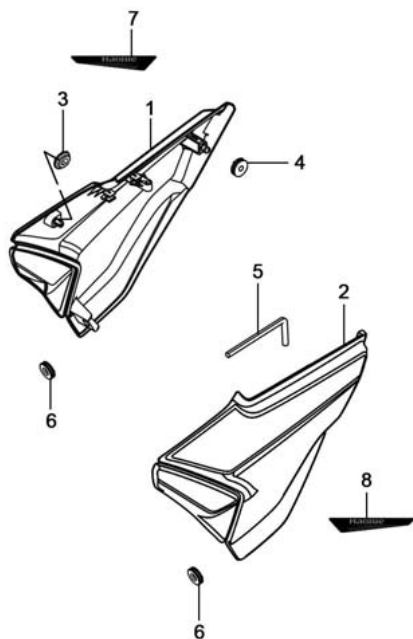

Fig.31 FRAME COVER (P10-S310-0001)

REF. No.	PART No.	DESCRIPTION	Q'TY	REMARKS
1	47111H17400H000	COVER, FRAME, R	1	
2	47211H17400H000	COVER, FRAME, L	1	
3	47312H02100H000	RUBBER CUSHION	2	
4	09320-08018-000	CUSHION, FRAME COVER REAR	2	
5	09816-05700-000	SPANNER	1	
6	09320-03004-000	CUSHION, FRAME COVER LOWER, R	2	
7	68135H17300HTC7	TAPE, FRAME COVER, R (TC7)	1	
7	68135H17300HTC9	TAPE, FRAME COVER, R (TC9)	1	
8	68136H17300HTC7	TAPE, COVER SIDE, L (TC7)	1	
8	68136H17300HTC9	TAPE, COVER SIDE, L (TC9)	1	

4



Fig. 32

Fig.32 FRONT FENDER (P10-S320-0001)

REF. No.	PART No.	DESCRIPTION	Q' TY	REMARKS
1	53110H17400H000	FENDER COMP, FRONT	1	
2	01580-0616A-000	HEXAGON HEAD BOLT SET WITH WASHER	4	
3	53115H17400H000	DUST CAP, FR FENDER	1	
4	09169-06082-000	WASHER, HELMET BOX CENTER	2	
5	01550-0616A-000	BOLT	2	
6	08316-1006A-000	NUT	2	
7	58621H17101H000	GUIDE, SPEEDOMETER CABLE	1	
8	01550-0610A-000	BOLTS, HEXAGON HEAD FLANGE	1	

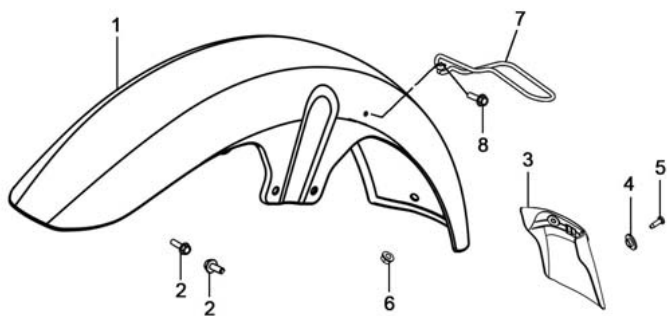

4



Fig. 33

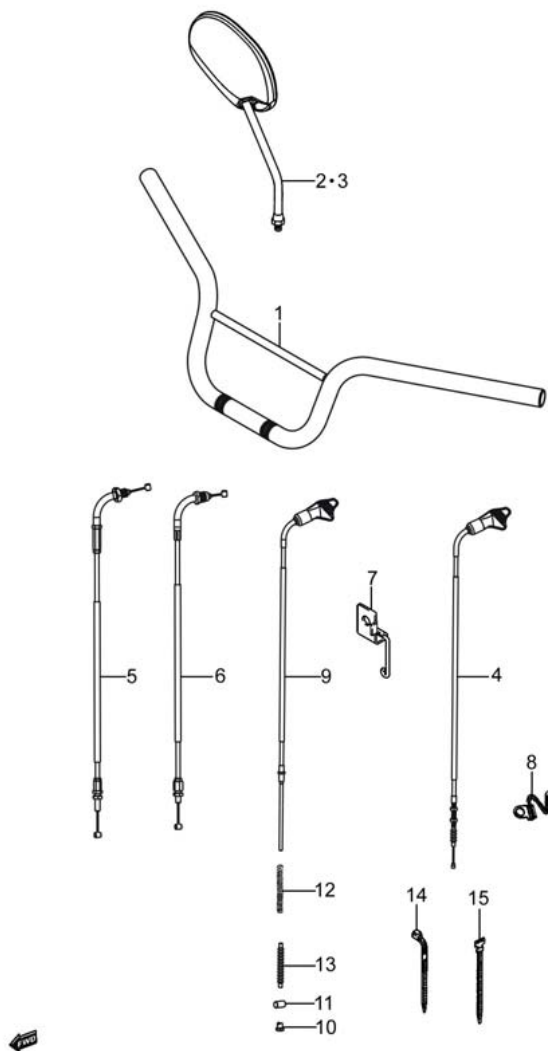

Fig.33 HANDLEBAR (P10-S330-0001)

REF. No.	PART No.	DESCRIPTION	Q'TY	REMARKS
1	56110H17400H000	HANDLEBAR COMP	1	
2	56500H17400H000	MIRROR ASSY, REAR VIEW, R	1	
3	56600H17400H000	MIRROR ASSY, REAR VIEW, L	1	
4	58200H17410H000	CABLE ASSY, CLUTCH	1	
5	58300H17410H000	CABLE ASSY, THROTTLE	1	
6	58410H17410H000	CABLE COMP, STARTER	1	
7	58620H05500H000	GUIDE COMP, CLUTCH CABLE	1	
8	58620H21G00H000	GUIDE COMP, FRONT BRAKE CABLE	1	
9	58110H17400H000	CABLE COMP, FRONT BRAKE	1	
10	09150H06001H000	NUT	1	
11	09209H12004H000	PIN	1	
12	09440H09003H000	SPRING, COMPRESSION	1	
13	09287H09001H000	SEAL, DUST	1	
14	09407-14403-000	CLAMP, FUEL HOSE	1	
15	09407-12402-000	CLAMP, WIRING HARNESS	1	

4

Fig. 34

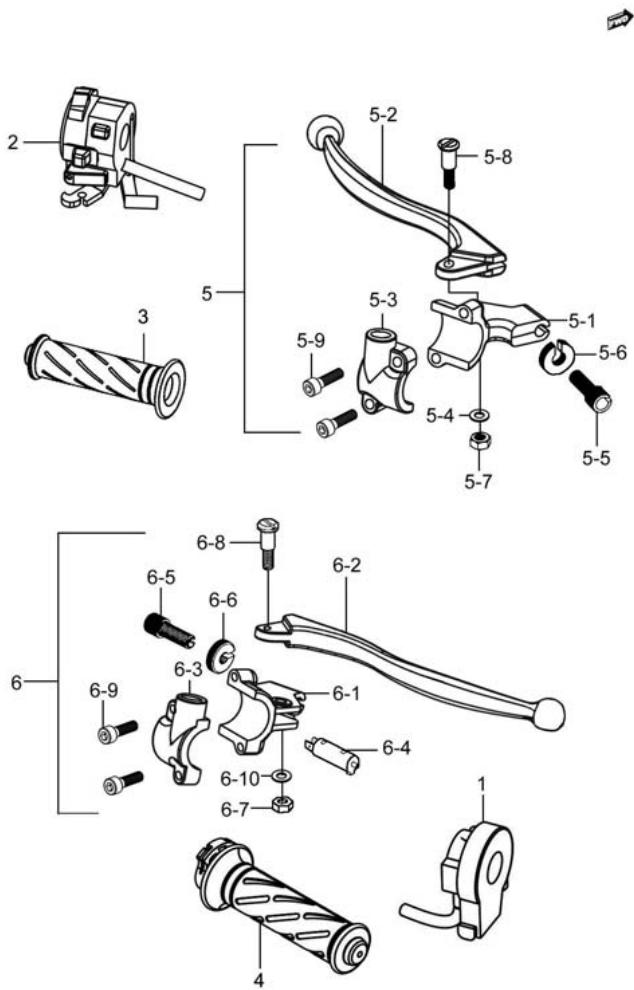

Fig.34 HANDLE SWITCH (P10-S340-0001)

REF. No.	PART No.	DESCRIPTION	Q' TY	REMARKS
1	37200H17400H000	SWITCH ASSY, HANDLE, R	1	
2	37400H17400H000	SWITCH ASSY, HANDLE, L	1	
3	57211H51000H000	GRIP, L	1	
4	57110H17400H000	GRIP COMP, THROTTLE	1	
5	57500H17111H000	LEVER ASSY, CLUTCH & SWITCH	1	
5-1	57511H17100H000	HOLDER, CLUTCH	1	
5-2	57621H17100H000	LEVER, CLUTCH	1	
5-3	57512H12900H000	HOLDER	1	
5-4	08321-2105B-000	SPRING LOCK WASHER	1	
5-5	57441H2J000H000	ADJUSTER, WIRE	1	
5-6	57442H12910H000	NUT, LOCK	1	
5-7	08310-0005B-000	HEXAGON NUT	1	
5-8	57431H12910H000	BOLT, LEVER PIVOT	1	
5-9	07130-0520B-000	HEXAGON SOCKET HEAD CAP SCREW	2	
6	57300H17100H000	LEVER ASSY, FR BRAKE & SWITCH	1	
6-1	57311H12900H000	HOLDER, FRONT BRAKE	1	
6-2	57421H12900H000	LEVER, FRONT BRAKE	1	
6-3	57512H12910H000	HOLDER	1	
6-4	57470H12900H000	SWITCH ASSY, BRAKE	1	
6-5	57441H12910H000	ADJUSTER, WIRE	1	
6-6	57442H12910H000	NUT, LOCK	1	
6-7	08310-0005B-000	HEXAGON NUT	1	
6-8	57431H12910H000	BOLT, LEVER PIVOT	1	
6-9	07130-0520B-000	HEXAGON SOCKET HEAD CAP SCREW	2	
6-10	08321-2105B-000	SPRING LOCK WASHER	1	

Fig. 35

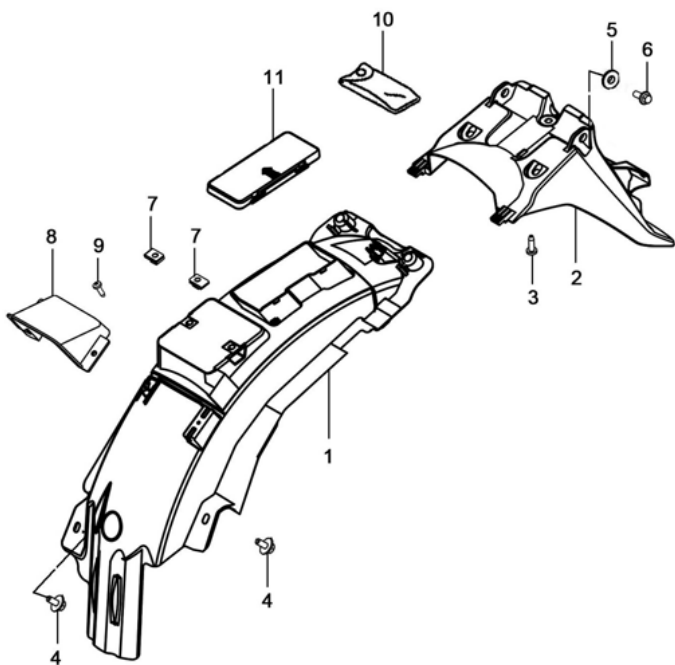

Fig.35 REAR FENDER (P10-S350-0001)

REF. No.	PART No.	DESCRIPTION	Q'TY	REMARKS
1	63112H17410H000	BODY, REAR FENDER, FRONT	1	
2	63113H17410H000	BODY, REAR FENDER, REAR	1	
3	09136H04003H000	SCREW WITH WASHER	2	
4	09118H06002H000	BOLT WITH WASHER	2	
5	09180H06025H000	SPACER	2	
6	01550-0620A-000	BOLTS, HEXAGON HEAD FLANGE	2	
7	35157H22500H000	NUT	2	
8	63152H17400H000	COVER, AIR CLEANER WATERPROOF	1	
9	03541-0412B-000	SCREW	2	
10	09800H20027H000	TOOL ASSY	1	
11	47432H17100H000	CAP, TOOL BOX	1	

4



Fig. 36

Fig.36 LABEL (P10-S370-0001)

REF. No.	PART No.	DESCRIPTION	Q' TY	REMARKS
1	99011H17400H000	MANUAL, OWNER ' S	1	
2	68332H17400H000	LABEL, TIRE INFORMATION	1	

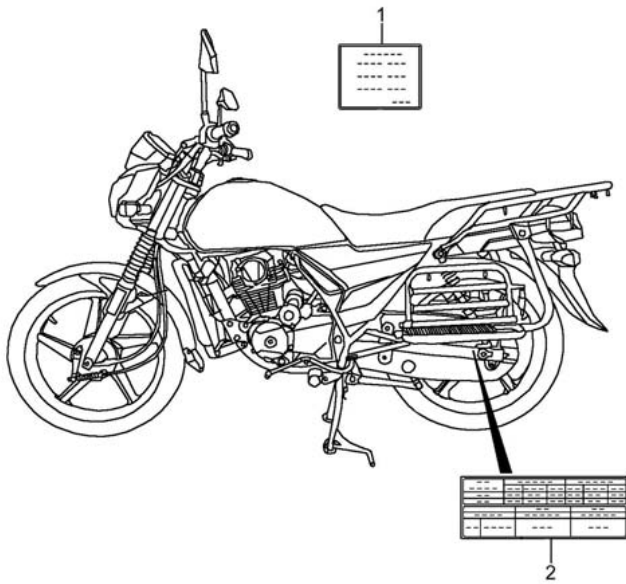

4

Fig. 37

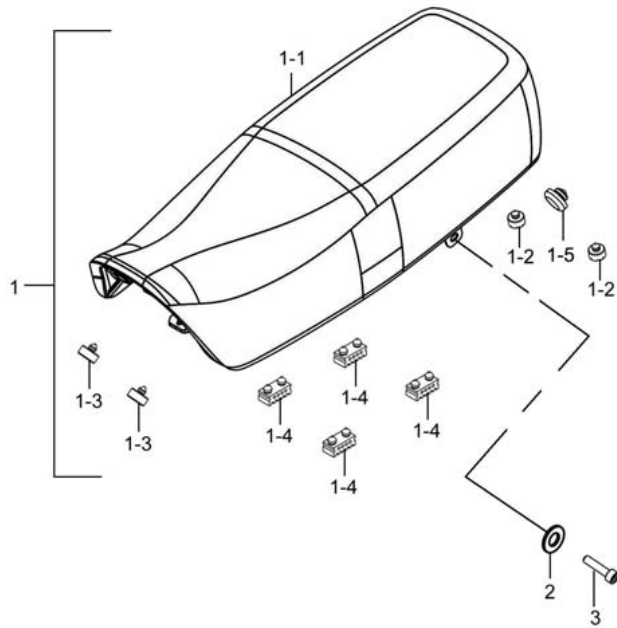

Fig.37 SEAT (P10-S380-0001)

REF. No.	PART No.	DESCRIPTION	Q'TY	REMARKS
1	45100H17300H000	SEAT ASSY	1	
1-1	45160H17300H000	COVER COMP, SEAT	1	
1-2	45148H52100H000	CUSHION, SEAT MOUNT	2	
1-3	45148-33G00-000	CUSHION, SEAT MOUNT REAR	2	
1-4	45149-45F00-000	CUSHION, RUBBER	4	
1-5	09329-10001-000	CUSHION	1	
2	08322-0108A-000	PLAIN WASHER	2	
3	07130-0816B-000	SCREWS, HEXAGON SOCKET HEAD CAP	2	

4



Fig. 38

Fig.38 STEERING STEM (P10-S400-0001)

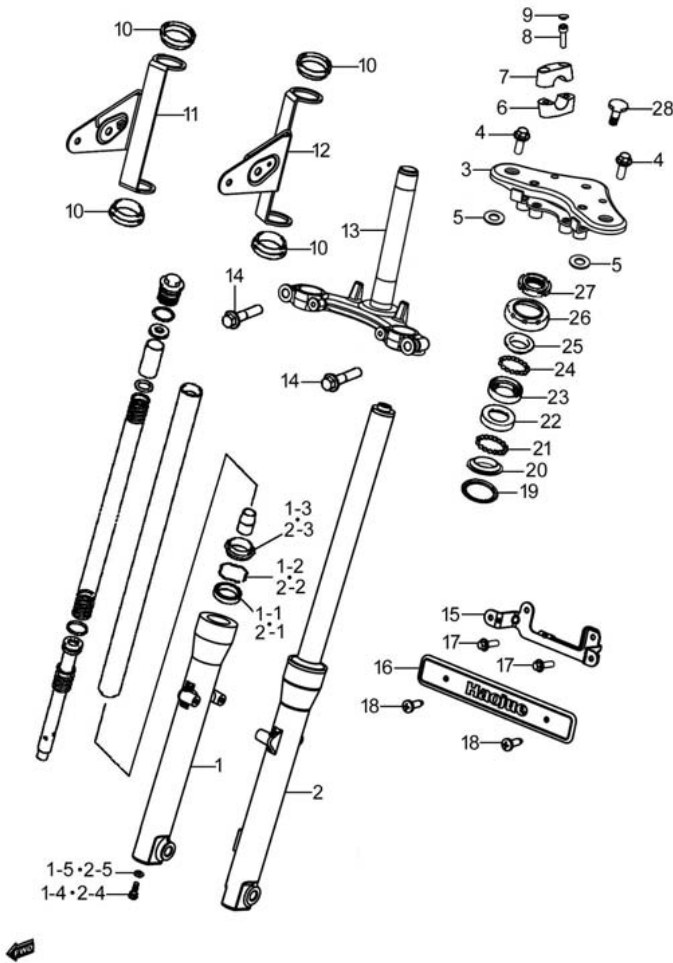

REF. No.	PART No.	DESCRIPTION	Q' TY	REMARKS
1	51103H17400H000	DAMPER ASSY, FRONT FORK, R	1	
1-1	51153-45F40-000	OIL SEAL	1	
1-2	51156-45F40-000	RING, OIL SEAL STOPPER	1	
1-3	51173-33GA0-000	COVER, DUST SEAL	1	
1-4	51147-45F40-000	BOLT	1	
1-5	51148-45F40-000	GASKET	1	
2	51104H17400H000	DAMPER ASSY, FRONT FORK, L	1	
2-1	51153-45F40-000	OIL SEAL	1	
2-2	51156-45F40-000	RING, OIL SEAL STOPPER	1	
2-3	51173-33GA0-000	COVER, DUST SEAL	1	
2-4	51147-45F40-000	BOLT	1	
2-5	51148-45F40-000	GASKET	1	
3	51310H17400H000	BRACKET COMP, UPPER	1	
4	51352H2C001H000	BOLT	2	
5	09161H30001H000	WASHER	2	
6	56221-45F10-000	HOLDER, HANDLE LOWER	2	
7	56211-45F10-000	HOLDER, HANDLE UPPER	2	
8	07130-0845A-000	HEXAGON SOCKET HEAD CAP SCREW	4	
9	09250-06011-000	CAP, BOLT	4	
10	51553-29311-000	DAMPER, HEADLAMP BRACKET	4	
11	51530H17400H000	BRACKET COMP, HEADLAMP, R	1	
12	51540H17400H000	BRACKET COMP, HEADLAMP, L	1	
13	51410H17300H000	BRACKET COMP, UNDER	1	
14	01550-1035A-000	BOLTS, HEXAGON HEAD FLANGE	2	
15	51880H17400H000	BRACKET COMP, FRONT FORK COVER	1	
16	53185H17400H000	FENDER, LEG FRONT SHIELD, LOWER	1	
17	01550-0610A-000	BOLTS, HEXAGON HEAD FLANGE	2	
18	02142-0616B-000	SCREW	2	
19	51644-45FA0-000	SEAL, STEERING, LOWER	1	

Fig. 38

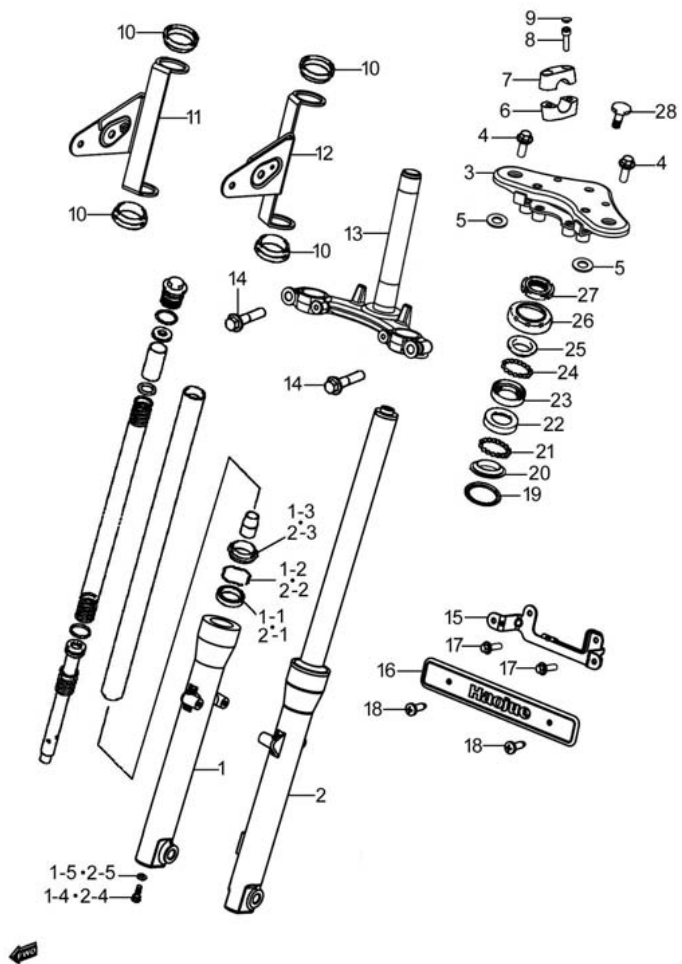

Fig.38 STEERING STEM (P10-S400-0001)

REF. No.	PART No.	DESCRIPTION	Q' TY	REMARKS
20	51622H2A200H000	RACE, STEERING OUTER LOWER	1	
21	51620H2A200H000	BALL, STEERING STEEL LOWER	1	
22	51612H2A200H000	RACE, STEERING INNER LOWER	1	
23	51611H2A201H000	RACE, STEERING INNER UPPER	1	
24	51610H2A200H000	BALL, STEERING STEEL UPPER	1	
25	51621H2A200H000	RACE, STEERING OUTER, UPPER	1	
26	51643H2A200H000	SEAL, STEERING DUST UPPER	1	
27	51631-48H00-000	NUT, STEERING STEM	1	
28	51352-45FA0-000	BOLT	1	

4

Fig. 39

Fig.39 FRONT WHEEL (P10-S410-0001)

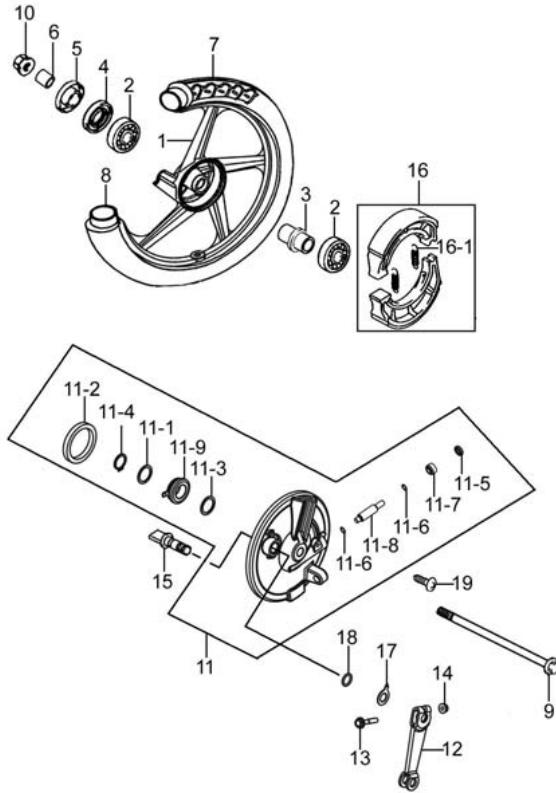

REF. No.	PART No.	DESCRIPTION	Q' TY	REMARKS
1	54110H17400H000	WHEEL COMP, FRONT	1	
2	08133-63017-000	BEARING, FRONT HUB	2	
3	54750H11200H000	SPACER	1	
4	54742-45F00-000	SEAL, FRONT HUB	1	
5	54892-45F00-000	COVER, FRONT HUB DUST SEAL	1	
6	54741H2A000H000	SPACER, FRONT AXLE, R	1	
7	55100H17410H000	TIRE SET, FR	1	
8	65200H50020H000	TUBE ASSY, WHEEL INNER	1	
9	54711H50000H000	AXLE, FRONT	1	
10	08319-3112A-000	U-NUT	1	
11	54200H17410H000	PANEL ASSY, FRONT BRAKE	1	
11-1	54613H11200H000	WASHER	1	
11-2	54267-36H00-000	SEAL, FRONT BRAKE PANEL OIL	1	
11-3	54614H11200H000	WASHER	1	
11-4	08331-31208-000	CIRCLIP	1	
11-5	54626H11200H000	OIL SEAL	1	
11-6	54623H11200H000	THRUST WASHER	2	
11-7	54632H12930H000	BUSH, SPEEDOMETER PINION	1	
11-8	54621H17400H000	PINION, SPEEDOMETER	1	
11-9	54610H17400H000	DRIVER COMP, SPEEDOMETER GEAR	1	
12	54451H11230H000	LEVER, FRONT BRAKE CAM	1	
13	01550-0633A-000	BOLT, HEXAGON HEAD FLANGE	1	
14	08316-1006A-000	NUT	1	
15	54441H12B10H000	CAM, FRONT BRAKE	1	
16	54400H7DY00H000	SHOE COMP, BRAKE	1	
16-1	55421-45F10-000	SPRING, BRAKE SHOE	2	
17	54492H11201H000	PLATE, FR BK LINING INDICATOR	1	
18	09280-14003-000	O-RING, REAR BRAKE CAM	1	
19	02132-0516A-000	SCREW	1	

4

Fig. 40

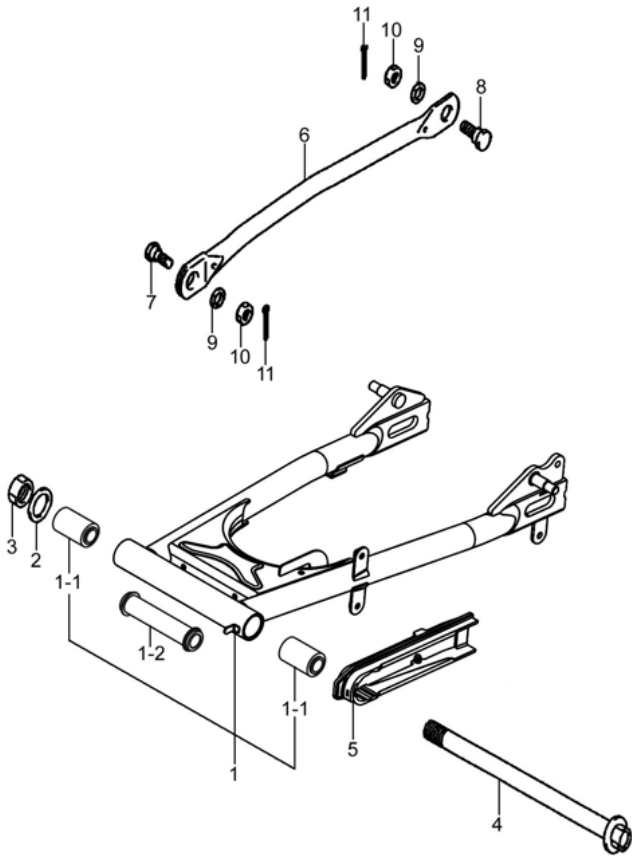

Fig.40 REAR SWINGING ARM (P10-S440-0001)

REF. No.	PART No.	DESCRIPTION	Q'TY	REMARKS
1	61019H17400H000	SWINGINGARM SET, REAR	1	
1-1	61200H45F00H000	SPACER, RR SWGARM PIVOT	2	
1-2	61280H2E100H000	SPACER COMP, RR SWGARM PIVOT	1	
2	08322-0114A-000	PLAIN WASHER	1	
3	08319-2114A-000	U-NUT	1	
4	61211H2E100H000	SHAFT, RR SWG ARM PIVOT	1	
5	61273H17400H000	BUFFER, CHAIN TOUCH DEFENSE	1	
6	64310H12901H000	TORQUELINK COMP, REAR	1	
7	64321-29J00-000	BOLT, RR TORQUELINK FRONT	1	
8	09111-08013-000	BOLT	1	
9	09162-08008-000	LOCK WASHER, RR TORQUELINK	2	
10	09140H08001H000	NUT	2	
11	04111-2020A-000	COTTER PIN	2	

4

Fig. 41

Fig.41 REARSHOCK ABSORBER (P10-S450-0001)

REF. No.	PART No.	DESCRIPTION	Q' TY	REMARKS
1	62100H17400H000	ABSORBER ASSY, REAR SHOCK	2	
2	09160H10001H000	WASHER, PLAIN	6	
3	09160-12090-000	WASHER, RR SHK ABS INNER	4	
4	09145H10003H000	NUT, CAP	4	
5	61310H17400H000	CASE COMP, CHAIN UPPER	1	
6	61320H17400H000	CASE COMP, CHAIN LOWER	1	
7	01560-0608A-000	HEXAGON HEAD BOLT	2	
8	09103H06007H000	BOLT	2	
9	09250H34001H000	CAP	1	
10	61395H17410H000	TAPE, CHAIN CASE	1	

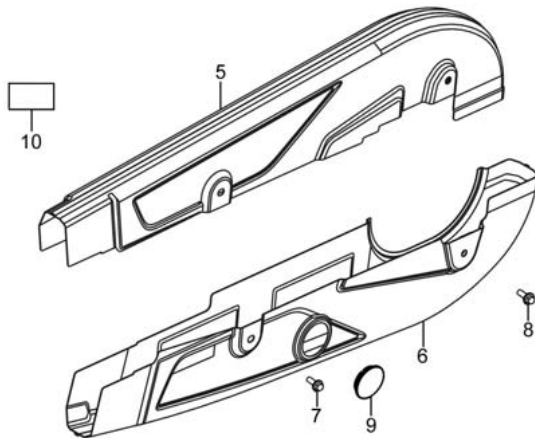
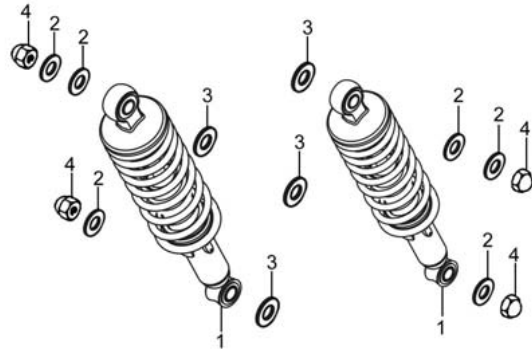

4

Fig. 42

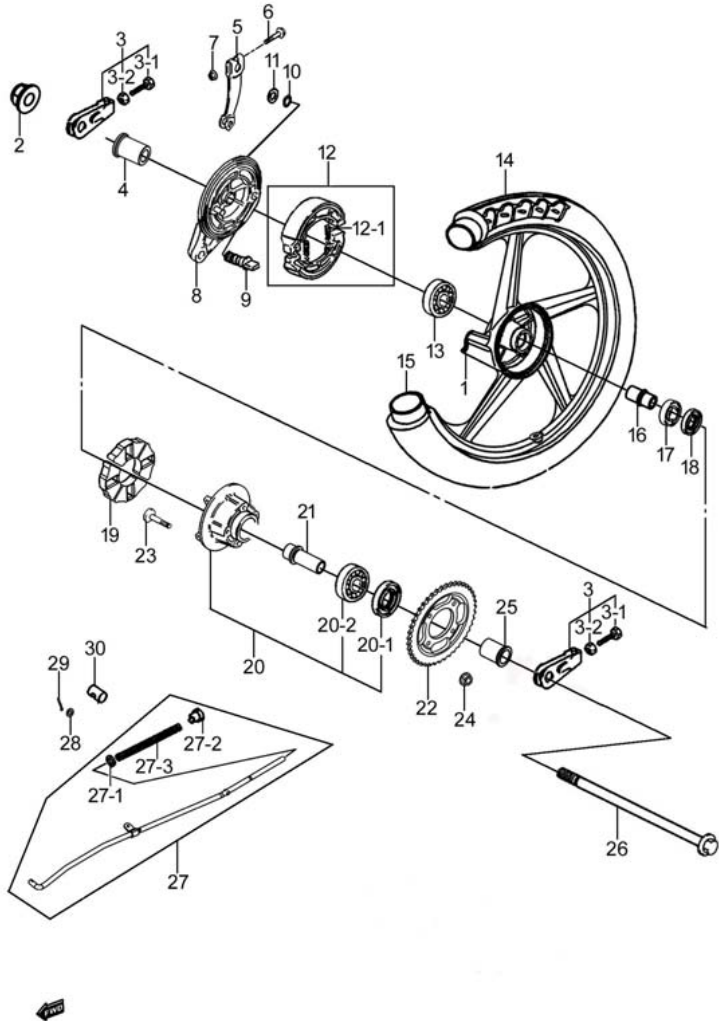

Fig.42 REAR WHEEL (P10-S460-0001)

REF. No.	PART No.	DESCRIPTION	Q'TY	REMARKS
1	64150H17400H000	WHEEL COMP, REAR	1	
2	08319-3114A-000	U-NUT	1	
3	61041H36020H000	ADJUSTER SET, CHAIN	2	
3-1	09104-080A6-000	BOLT	1	
3-2	08310-0008A-000	HEXAGON NUT	1	
4	64741H17400H000	SPACER, REAR AXLE, R	1	
5	64451H12B10H000	LEVER, REAR BRAKE CAM	1	
6	01550-0633A-000	BOLT, HEXAGON HEAD FLANGE	1	
7	08316-1006A-000	NUT	1	
8	64210H11000H000	PANEL COMP, REAR BRAKE	1	
9	64441H12B10H000	CAM, REAR BRAKE	1	
10	09280-14003-000	O-RING, REAR BRAKE CAM	1	
11	64492H11200H000	FINGER, REAR BRAKE	1	
12	54400H7DY00H000	SHOE COMP, BRAKE	2	
12-1	55421-45F10-000	SPRING, BRAKE SHOE	2	
13	08144-63027-000	BEARING, REAR HUB	1	
14	65100H17410H000	TIRE SET, RR	1	
15	65200H17410H000	TUBE ASSY, WHEEL INNER	1	
16	64916H17400H000	SPACER COMP, REAR HUB	1	
17	08143-62027-000	BEARING	1	
18	64810H11200H000	OIL SEAL, REAR WHEEL	1	
19	64651H17400H000	ABSORBER, REAR HUB SHOCK	4	
20	64610H12800H000	DRUM COMP, REAR SPROCKET	1	
20-1	64612H11200H000	OIL SEAL	1	
20-2	08143-60047-000	BEARING	1	
21	64733H17400H000	RETAINER, REAR SPROCKET DRUM	1	
22	64511H17410H000	SPROCKET, REAR	1	
23	09119H08003H000	BOLT	4	
24	08319-3108A-000	NUT	4	

4

Fig. 42

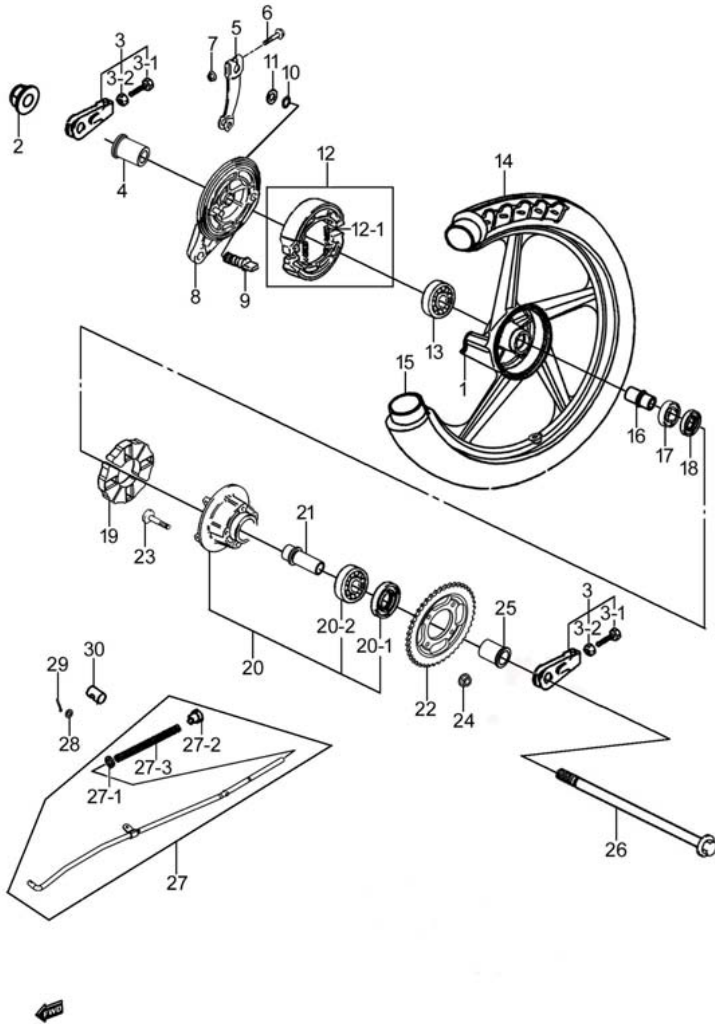

Fig.42 REAR WHEEL (P10-S460-0001)

REF. No.	PART No.	DESCRIPTION	Q' TY	REMARKS
25	64614H17300H000	BUSH, RR SPROCKET DRUM	1	
26	64711H2A000H000	AXLE, REAR	1	
27	43031H17400H000	ROD SET, REAR BRAKE	1	
27-1	08322-0106A-000	WASHER, PLAIN	1	
27-2	09150-06001-000	NUT, REAR BRAKE ROD ADJUSTER	1	
27-3	09440H09007H000	SPRING, COMPRESSION	1	
28	08322-0106A-000	WASHER, PLAIN	1	
29	04111-2015A-000	COTTER PIN	1	
30	43321H11200H000	PIN	1	

Fig. 43

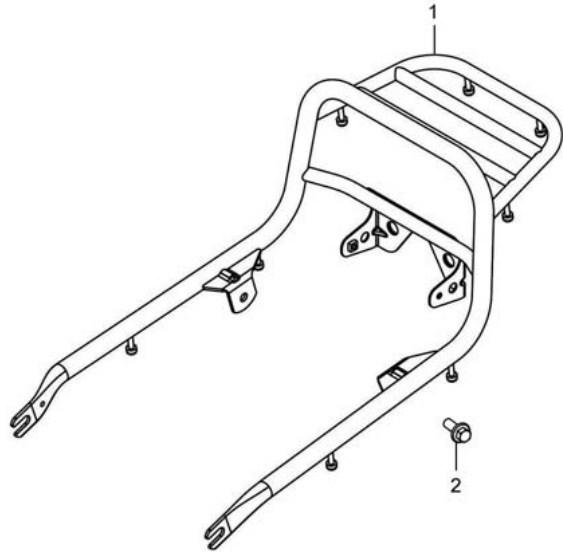

Fig.43 CARRIER (P10-S480-0001)

REF. No.	PART No.	DESCRIPTION	Q'TY	REMARKS
1	46310H17300H000	CARRIER COMP, REAR	1	
2	01550-0816A-000	HEXAGON BOLT WITH FLANGE	2	

PART NO.	FIG. NO. – REF. NO.	PART NO.	FIG. NO. – REF. NO.	PART NO.	FIG. NO. – REF. NO.	PART NO.	FIG. NO. – REF. NO.
00000		01550-0633A-000	42-6	07130-0825A-000	11-2	08322-01087-000	22-6
		01550-0812A-000	21-2	07130-0845A-000	38-8	08322-0108A-000	37-2
		01550-0816A-000	43-2	08110-62030-000	14-3	08322-0114A-000	40-2
		01550-0820A-000	28-11	08110-62030-000	14-6	08331-31149-000	15-15-2
		01550-0845A-000	28-12	08133-63017-000	39-2	08331-31189-000	16-4
01204-08207-000	22-4	01550-1020A-000	28-13	08143-60047-000	42-20-2	08331-31208-000	39-11-4
01500-0820A-000	15-19	01550-1025B-000	28-3	08143-62027-000	42-17	08331-31209-000	16-1-9
01500-0825A-000	16-6	01550-1035A-000	38-14	08144-63027-000	42-13	08361-3506A-000	20-2
01547-0512A-000	01-15	01550-1050A-000	28-7	08310-0005B-000	34-5-7	09100H06022H000	15-11
01547-0612A-000	01-12	01560-0608A-000	41-7	08310-0005B-000	34-6-7	09100H06022H000	15-14
01547-0616A-000	18-2	01580-0616A-000	32-2	08310-0006A-000	01-22	09103H05001H000	07-7
01547-0616A-000	03-7	02112-0406A-000	29-3	08310-0008A-000	42-3-2	09103H06003H000	01-6
01547-0620A-000	08-7	02112-0418A-000	15-21	08310-11063-000	21-1-10	09103H06007H000	41-8
01547-0625A-000	12-2	02112-1520A-000	20-9	08316-1005A-000	24-6	09103H10003H000	03-10
01547-0625A-000	18-3	02122-0512A-000	05-9	08316-1006A-000	24-2	09103H10010H000	03-9
01547-0630A-000	01-11	02132-0516A-000	39-19	08316-1006A-000	30-4	09103H10013H000	26-4
01547-0630A-000	17-2	02142-0516A-000	10-1-11	08316-1006A-000	32-6	09104-080A6-000	42-3-1
01547-0630A-000	04-13	02142-0516B-000	23-3	08316-1006A-000	39-14	09108H06009H000	01-21
01547-0640A-000	04-4	02142-0616B-000	38-18	08316-1006A-000	42-7	09108H08011H000	02-3
01547-0645A-000	03-3	03541-0412B-000	25-7	08316-1008A-000	01-3	09111-08013-000	40-8
01547-0655A-000	03-2	03541-0412B-000	35-9	08316-1012A-000	18-4	09111H10060H000	27-9
01550-0610A-000	26-6	03541-0416A-000	25-9	08319-2114A-000	40-3	09116-06084-000	29-6
01550-0610A-000	32-8	03541-0516A-000	10-1-5	08319-3108A-000	42-24	09116H06004H000	07-4
01550-0610A-000	38-17	03541-0616B-000	25-11	08319-3110A-000	03-11	09118H06002H000	35-4
01550-0612A-000	10-3	04111-2015A-000	28-5-5	08319-3110A-000	26-3	09119H08003H000	42-23
01550-0612A-000	20-5	04111-2015A-000	28-6-5	08319-3110A-000	27-10	09125H06002H000	08-8
01550-0612A-000	25-12	04111-2015A-000	42-29	08319-3110A-000	28-8	09128-06004-000	20-3
01550-0612A-000	25-21	04111-2020A-000	40-11	08319-3112A-000	39-10	09136H04003H000	35-3
01550-0616A-000	10-2	04111-2525A-000	27-4	08319-3114A-000	42-2	09139-06048-000	25-18
01550-0616A-000	20-7	04211-11129-000	02-4	08321-01087-000	22-5	09139H06016H000	11-1-2
01550-0616A-000	32-5	04211-11169-000	01-5	08321-2105B-000	34-5-4	09140H08001H000	40-10
01550-0620A-000	01-23	07130-0520B-000	34-5-9	08321-2105B-000	34-6-10	09145H10003H000	41-4
01550-0620A-000	35-6	07130-0520B-000	34-6-9	08322-01063-000	21-1-9	09150-06001-000	42-27-2
01550-0625A-000	13-2-1	07130-0610A-000	14-10	08322-0106A-000	42-27-1	09150H06001H000	33-10
01550-0633A-000	39-13	07130-0816B-000	37-3	08322-0106A-000	42-28	09160-06088-000	24-4

5

PART NO.	FIG. NO. – REF. NO.	PART NO.	FIG. NO. – REF. NO.	PART NO.	FIG. NO. – REF. NO.	PART NO.	FIG. NO. – REF. NO.
09160-06159-000	11-1-3	09247-10001-000	01-7	09401H08302H000	30-3	11091H3H000H000	04-14
09160-08039-000	01-4	09247H12105H000	03-4	09401H13201H000	10-1-8	11110H3H000H000	01-1
09160-12090-000	41-3	09250-06011-000	38-9	09404-06433-000	25-6	11121H3H000H000	01-14
09160H10001H000	41-2	09250H34001H000	41-9	09407-11401-000	25-5	11141H3H000H000	01-2
09160H12014H000	14-1-7	09259H32002H000	04-8	09407-12402-000	25-3	11170H3H000H000	01-9
09160H15002H000	14-1-8	09261-02001-000	12-5	09407-12402-000	33-15	11173H3H000H000	01-10
09160H16004H000	05-11	09261H10008H000	06-1-4	09407-14403-000	25-2	11210H3H010H000	02-1
09160H17001H000	27-3	09262H12018H000	14-2	09407-14403-000	33-14	11241H3H000H000	02-2
09160H17002H000	14-4-13	09262H17001H000	13-7	09407-18402-000	25-4	11300H3HY00H000	03-1
09160H17004H000	14-4-14	09262H17007H000	14-7	09420H04002H000	05-5-1	11340H3H000H000	04-1
09160H17006H000	14-4-15	09262H30001H000	05-6	09421H04003H000	05-15	11351H3H000H000	04-6
09160H20001H000	14-4-11	09280-14003-000	39-18	09440H04017H000	06-1-6	11353H3J010H000	04-10
09161H30001H000	38-5	09280-14003-000	42-10	09440H04030H000	15-7	11360H17300H000	04-12
09162-08008-000	40-9	09280-32006-000	04-9	09440H09003H000	33-12	11421H3H000H000	04-5
09164-10012-000	07-8	09280H09011H000	08-9	09440H09007H000	42-27-3	11482H3H000H000	04-2
09166H18002H000	05-14	09280H13010H000	04-11	09443-19020-000	27-6	11483H3H000H000	04-7
09168-06018-000	01-13	09280H18002H000	04-14-1	09443H14004H000	27-15	12111H3H000H000	05-1
09168-10L01-000	01-8	09280H19001H000	15-22	09448H15001H000	04-16	12140H29000H000	05-2
09168H06002H000	11-1-4	09280H28002H000	01-18	09471-12077-000	21-1-6	12151H3H000H000	05-3
09168H12001H000	03-5	09280H32001H000	01-20	09471-12128-000	24-1-2	12200H3H000H000	05-5
09169-06082-000	32-4	09283-17025-000	14-5	09471-12177-000	23-1-2	12611H3H000H000	06-3
09180-06067-000	29-7	09283H14003H000	15-17	09471-12177-000	23-2-2	12612H3H000H000	06-4
09180-06263-000	24-5	09283H16001H000	16-3	09471-12177-000	23-4-2	12620H3H000H000	06-2
09180H06025H000	35-5	09287H09001H000	33-13	09471-12177-000	23-5-2	12630H33010H000	06-1
09180H08021H000	06-5	09289H05004H000	07-15	09471H12001H000	22-1-1-4	12631H33010H000	06-1-2
09181H14003H000	16-1-7	09320-03004-000	31-6	09482-00621-000	01-16	12632H33010H000	06-1-3
09181H14004H000	15-15-3	09320-08018-000	31-4	09491H11210H000	09-1-10	12633H33010H000	06-1-5
09181H20002H000	16-1-8	09320-08047-000	24-3	09494H12700H000	09-1-26	12642H33010H000	06-1-1
09200H06004H000	28-5-4	09320H10022H000	29-8	09800H20027H000	35-10	12710H3H000H000	07-1
09200H06004H000	28-6-4	09329-10001-000	37-1-5	09816-05700-000	31-5	12741H3H000H000	07-2
09205H03001H000	04-17	09380H18002H000	14-4-12			12742H16200H000	07-3
09206H08004H000	04-3	09380H18004H000	14-1-9			12760H20G00H000	08-1
09206H10007H000	03-1-1	09381-14001-000	05-4	10000		12771H3H000H000	08-2
09209H12004H000	33-11	09383-06001-000	12-4			12811H3H000H000	08-3
09229H03001H000	26-8	09401-11102-000	10-5			12812H3H000H000	08-4

PART NO.	FIG. NO. – REF. NO.	PART NO.	FIG. NO. – REF. NO.	PART NO.	FIG. NO. – REF. NO.	PART NO.	FIG. NO. – REF. NO.
12830H29011H000	08-5	13385H17300H000	09-1-9	20000		24312H3J000H000	14-4-3
12837H50100H000	08-6	13388H12700H000	09-1-20		24321H3H000H000	14-4-4	
12840H16200H000	07-5	13389H12700H000	09-1-17		24322H3J000H000	14-4-5	
12842H16200H000	07-5-1	13432H33000H000	09-1-16		24331H3H000H000	14-4-6	
12843H12000H000	07-5-2	13494H12700H000	09-1-23		24332H3J000H000	14-4-7	
12861H3H000H000	07-6	13551H17300H000	09-1-4	21111H3H010H000	05-13	24341H3H000H000	14-4-8
12911H16200H000	07-9	13573H17300H000	09-1-2	21113H3H000H000	05-12	24351H3H000H000	14-4-9
12912H16200H000	07-10	13683H17310H000	09-1-30	21200H3H000H000	13-1	24741H3J000H000	03-6
12921H3H000H000	07-14	13684H17300H000	09-1-25	21251H3H000H000	13-4	25211H3H010H000	15-1
12931H50100H000	07-11	13700H17400H000	10-1	21324H3J000H000	13-5	25231H3H010H000	15-2
12932H50100H000	07-12	13723H17400H000	10-1-7	21346H33000H000	05-10	25241H3H010H000	15-3
12933H16200H000	07-13	13741H17400H000	10-1-10	21346H3J000H000	13-6	25311H3H020H000	15-6
13111H3H000H000	01-17	13781H17300H000	10-1-4	21410H3H010H000	13-2	25314H3E000H000	15-8
13128H3H000H000	01-19	13810H17300H000	10-1-6	21411H3R000H000	13-2-7	25335H3J000H000	15-10
13170H2C002H000	10-1-3	13851H17300H000	10-4	21413H3H000H000	13-2-3	25350H3J000H000	15-12
13200H17310H000	09-1	13863H22500H000	10-1-9	21420H33000H000	13-2-5	25351H3J000H000	15-13
13224H2A000H000	09-1-29	13891H17300H000	10-1-1	21451H3E020H000	13-2-6	25380H3H010H000	15-9
13225H11200H000	09-1-19	14036H17400H000	11-1	21462H3R000H000	13-2-4	25411H3J000H000	15-4
13247H33000H000	09-1-14	14181-09D20-000	11-3	21471H3G000H000	13-2-2	25421H3J000H000	15-5
13251H11A10H000	09-1-11	14780H17400H000	11-1-1	21481H3J000H000	13-3	25500H3H000H000	15-15
13252H33000H000	09-1-12	16052H3D010H000	05-7	23121H3H000H000	13-9	25518H3J000H000	15-15-1
13253H33000H000	09-1-15	16330H3H000H000	12-3	23131H33030H000	13-8	25600H17300H000	15-18
13254H21D00H000	09-1-22	16400H3H000H000	12-1	23270H3H000H000	04-15	25652H16500H000	15-18-1
13255H11200H000	09-1-1	16514H3D000H000	05-7-1	23285H3H000H000	04-18	25671H3J000H000	15-16
13261H12700H000	09-1-28	16520-09410-000	03-8	24102H3H000H000	14-1	26210H3H000H000	16-1
13262H11200H000	09-1-13	16520H33040H000	05-7-2	24103H3H000H000	14-4	26211H3H000H000	16-1-1
13267H12700H000	09-1-5	16521H33040H000	05-7-2-2	24121H3H000H000	14-1-1	26221H16200H000	16-1-2
13268H33000H000	09-1-6	16531H33040H000	05-7-2-4	24131H3H000H000	14-4-1	26225H3H000H000	16-2
13270H12900H000	09-1-24	16532H33000H000	05-7-2-1	24221H3H000H000	14-1-2	26226H3H000H000	16-1-3
13279H17300H000	09-1-7	16551H33040H000	05-7-2-3	24231H3H000H000	14-1-3	26235H16200H000	16-1-4
13295H21D00H000	09-1-18	16561H33000H000	05-8	24232H3H000H000	14-1-6	26241H3H000H000	16-1-5
13299H12700H000	09-1-27			24232H3J000H000	14-4-10	26282H16200H000	16-1-6
13351H17300H000	09-1-8			24241H3H000H000	14-1-4	26300H3H010H000	16-5
13370H21D00H000	09-1-21			24251H3H000H000	14-1-5	26352H3H000H000	16-5-1
13383H17300H000	09-1-3			24311H3H010H000	14-4-2	27511-36H00-000	14-8

PART NO.	FIG. NO. – REF. NO.	PART NO.	FIG. NO. – REF. NO.	PART NO.	FIG. NO. – REF. NO.	PART NO.	FIG. NO. – REF. NO.
27512-09G00-000	14-9	34150H17400H000	21-1-1	36651-26H60-000	25-8	43321H11200H000	42-30
27600H2A010H106	14-11	34152H2A430H000	21-1-3	36651H17300H000	25-13	43501H17401H000	28-1
		34173H17400H000	21-1-4	36651H3H000H000	17-3	43502H17100H000	28-2
		34193H12E00H000	21-1-5	36720H2C100H000	25-1-1	43551H17100H000	28-1-1
		34810H17400H000	30-5	36990-39J00-000	25-15	43551H17100H000	28-2-1
30000		34910H12E01H000	21-3	37011H2E01AH000	25-22	43600H2A210H000	28-5
		34950H2A430H000	21-1-7	37100H2E010H000	25-17	43610H17400H000	28-9
		34955-45F20-000	21-1-8	37200H17400H000	34-1	43612H2A200H000	28-5-2
		35011H17400H000	22-1	37400H17400H000	34-2	43612H2A200H000	28-6-2
		35100H17400H000	22-1-1	37720H17310H000	15-20	43621H2A200H000	28-5-1
31100H3H000H000	17-1	35111H2A410H000	22-1-1-2	37740H2J000H000	25-19	43621H2A200H000	28-6-1
31133H3H000H000	17-1-8	35121H17400H000	22-1-1-1	38500H2C000H000	25-20	43631H52100H000	28-5-3
31135H3H000H000	17-1-9	35128H2A410H000	22-1-1-6	38610H11222H000	23-6	43631H52100H000	28-6-3
31153H3H000H000	17-1-4	35157H22500H000	35-7			43700H2A210H000	28-6
31156H3H000H000	17-1-3	35157H37200H000	10-1-2			43710H17400H000	28-10
31156H3H010H000	17-1-7	35172H2A410H000	22-1-1-5	40000		44011H17400HF01	29-1
31156H3H020H000	17-1-5	35174H2A410H000	22-1-1-3			44011H17400HF02	29-1
31175H3H000H000	17-1-1	35181-45F10-000	22-1-2			44011H17400HF03	29-1
31281H3H000H000	17-1-6	35601H17400H000	23-1			44011H17400HF04	29-1
31800-49110-000	20-1	35602H17400H000	23-2			44200H11750H000	29-2
32100H3H000H000	18-1	35603H56001H000	23-4	41100H17Y20H000	26-1	44300H2A240H000	30-1
32101H3H000H000	18-1-1	35604H56001H000	23-5	41560H17400H000	26-5	44421H17300H000	30-2
32102H3H000H000	18-1-2	35652H56000H000	23-2-1	41992H17300H000	26-2	44541H11200H000	29-4
32491H33010H000	18-5	35652H56000H000	23-4-1	42100H17400H000	27-1	44542-38300-000	29-5
32800H05523H000	20-4	35672H56000H000	23-1-1	42112H2D001H000	27-5	45100H17300H000	37-1
32900H17310H000	20-6	35672H56000H000	23-5-1	42211H17100H000	27-2	45148-33G00-000	37-1-3
33410H17300H000	20-8	35710H17400H000	24-1	42241-26H10-000	27-8	45148H52100H000	37-1-2
33510-04H10-000	20-8-1	35712H17400H000	24-1-1	42278-26H00-000	11-1-5	45149-45F00-000	37-1-4
33541H05500H000	20-8-2	35713H17400H000	24-1-3	42310H17400H000	27-7	45160H17300H000	37-1-1
33542H05500H000	20-8-3	35970H2F000H000	24-7	43031H17400H000	42-27	46310H17300H000	43-1
33610H17400H000	19-1	36610H17400H000	25-1	43110H17400H000	27-11	47111H17400H000	31-1
33810H3H000H000	17-1-2	36618H2A000H000	25-16	43115H36600H000	27-13	47211H17400H000	31-2
33860H17300H000	19-2	36619H17100H000	25-10	43116H22500H000	27-14	47312H02100H000	31-3
34100H17400H000	21-1	36651-12F10-000	25-14	43125H2A203H000	27-12	47432H17100H000	35-11
34111H17400H000	21-1-2	36651-26H60-000	09-2	43125H2A203H000	28-4		

PART NO.	FIG. NO. – REF. NO.	PART NO.	FIG. NO. – REF. NO.	PART NO.	FIG. NO. – REF. NO.	PART NO.	FIG. NO. – REF. NO.	
50000		51811-45F20-000	22-1-3	57110H17400H000	34-4	61280H2E100H000	40-1-2	
		51825-45F10-000	22-2	57211H51000H000	34-3	61310H17400H000	41-5	
		51827-45F10-000	22-3	57300H17100H000	34-6	61320H17400H000	41-6	
		51880H17400H000	38-15	57311H12900H000	34-6-1	61395H17410H000	41-10	
		53110H17400H000	32-1	57421H12900H000	34-6-2	62100H17400H000	41-1	
51103H17400H000	38-1	53115H17400H000	32-3	57431H12910H000	34-5-8	63112H17410H000	35-1	
51104H17400H000	38-2	53185H17400H000	38-16	57431H12910H000	34-6-8	63113H17410H000	35-2	
51147-45F40-000	38-1-4	54110H17400H000	39-1	57441H12910H000	34-6-5	63152H17400H000	35-8	
51147-45F40-000	38-2-4	54200H17410H000	39-11	57441H2J000H000	34-5-5	64150H17400H000	42-1	
51148-45F40-000	38-1-5	54267-36H00-000	39-11-2	57442H12910H000	34-5-6	64210H11000H000	42-8	
51148-45F40-000	38-2-5	54400H7DY00H000	39-16	57442H12910H000	34-6-6	64310H12901H000	40-6	
51153-45F40-000	38-1-1	54400H7DY00H000	42-12	57470H12900H000	34-6-4	64321-29J00-000	40-7	
51153-45F40-000	38-2-1	54441H12B10H000	39-15	57500H17111H000	34-5	64441H12B10H000	42-9	
51156-45F40-000	38-1-2	54451H11230H000	39-12	57511H17100H000	34-5-1	64451H12B10H000	42-5	
51156-45F40-000	38-2-2	54492H11201H000	39-17	57512H12900H000	34-5-3	64492H11200H000	42-11	
51173-33GA0-000	38-1-3	54610H17400H000	39-11-9	57512H12910H000	34-6-3	64511H17410H000	42-22	
51173-33GA0-000	38-2-3	54613H11200H000	39-11-1	57621H17100H000	34-5-2	64610H12800H000	42-20	
51310H17400H000	38-3	54614H11200H000	39-11-3	58110H17400H000	33-9	64612H11200H000	42-20-1	
51352-45FA0-000	38-28	54621H17400H000	39-11-8	58200H17410H000	33-4	64614H17300H000	42-25	
51352H2C001H000	38-4	54623H11200H000	39-11-6	58300H17410H000	33-5	64651H17400H000	42-19	
51410H17300H000	38-13	54626H11200H000	39-11-5	58410H17410H000	33-6	64711H2A000H000	42-26	
51530H17400H000	38-11	54632H12930H000	39-11-7	58620H05500H000	33-7	64733H17400H000	42-21	
51540H17400H000	38-12	54711H50000H000	39-9	58620H21G00H000	33-8	64741H17400H000	42-4	
51553-29311-000	38-10	54741H2A000H000	39-6	58621H17101H000	32-7	64810H11200H000	42-18	
51610H2A200H000	38-24	54742-45F00-000	39-4			64916H17400H000	42-16	
51611H2A201H000	26-1-1	54750H11200H000	39-3			65100H17410H000	42-14	
51611H2A201H000	38-23	54892-45F00-000	39-5			65200H17410H000	42-15	
51612H2A200H000	26-1-2	55100H17410H000	39-7	60000		65200H50020H000	39-8	
51612H2A200H000	38-22	55421-45F10-000	39-16-1				68135H17300HTC7	31-7
51620H2A200H000	38-21	55421-45F10-000	42-12-1				68135H17300HTC9	31-7
51621H2A200H000	38-25	56110H17400H000	33-1				68136H17300HTC7	31-8
51622H2A200H000	38-20	56211-45F10-000	38-7				68136H17300HTC9	31-8
51631-48H00-000	38-27	56221-45F10-000	38-6	61019H17400H000	40-1	68311H56110H000	26-7	
51643H2A200H000	38-26	56500H17400H000	33-2	61041H36020H000	42-3	68332H17400H000	36-2	
51644-45FA0-000	38-19	56600H17400H000	33-3	61200H45F00H000	40-1-1			
				61211H2E100H000	40-4			
				61273H17400H000	40-5			

PART NO.	FIG. NO. - REF. NO.
90000	
99011H17400H000	36-1

5

Haojue XPRESS PARTS CATALOGUE

1st Edition

Published in 2019.9

DACHANGJIANG GROUP CO.,LTD.

No.5, Jiandabei Rd., Jiangmen City, Guangdong Province, P.R.China

Tel: 86-750-3288999 Fax: 86-750-3230989 Code: 529000

DACHANGJIANG GROUP COPYRIGHT POSSESSION.



DACHANGJIANG GROUP CO. , LTD.

